

DustAlarm® ES Broken Bag Detector

Latest
Generation

FEATURES & ADVANTAGES

- ▼ **Easy Set-up and Calibration...Set it and forget it!**
 - ▼ The easy auto set-up function is activated by pressing a button to automatically establish a “clean air baseline”, scale the operating range and set the alarms.
 - ▼ Quick-connect mounting provides for ease of installation or maintenance.
- ▼ **Safety and Cost-Savings Benefits**
 - ▼ Monitor the efficiency of dust collection systems and know the optimal time to replace filters.
 - ▼ Monitor for unexpected events that can cost time, money, material loss, equipment damage and other problems.
 - ▼ Economical dust monitoring that provides an alternative to opacity detection.
- ▼ **Digital Communications and Software Capabilities**
 - ▼ Digital RS-485(Modbus) connection as an alternative to relay output and/or for connecting multiple sensors to one control system.
 - ▼ Connect with the free **DustConfig™** software to set custom alarm points, view live activity within the duct, or review data history for up to a 24-hour period.
- ▼ **Exceptional and Reliable Sensitivity**
 - ▼ Uses proven AC Triboelectric technology with advanced algorithms to filter out noise and provide the most accurate dust measurement.
 - ▼ Capable of detecting minute amounts of particles passing the probe.
 - ▼ Excellent repeatability not affected by variations in relative humidity, process temperature or pressure.
 - ▼ Unique probe design with extended Ryton® insulator helps protect the unit from false signaling due to product build up.

Practical Tip
DustAlarm ES is ideal for detecting early failure of a filter within a baghouse before a catastrophic tear creates an environmental disaster.

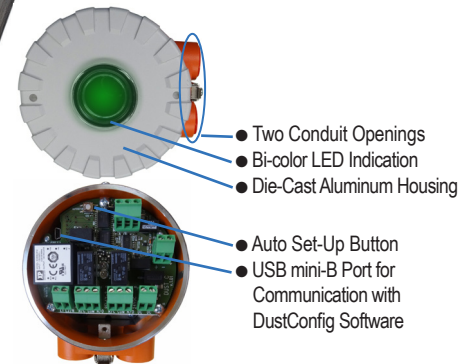

PRINCIPLE OF OPERATION

AC Triboelectric technology has been used for broken bag detection for many years and is an accepted technology by the US EPA for dust particle emission detection (40 CFR Sec 63.1350).

The Triboelectric effect is based on particles interacting with an electrically isolated sensing probe. When moving particles pass in close proximity to the probe a very small electrical charge is transferred from the particulate to the probe. This electrical signal is then processed by the **DustAlarm® ES** via a series of advanced algorithms. The signal processing filters out other electrical charges, or electrical ‘noise’, which is not representative of the moving particles. These proprietary algorithms effectively differentiate undesirable signals from the desirable signal resulting in reliable particle emissions detection.

The **DustAlarm® ES** is designed to detect a change in the concentration of dust within the exhaust air stream of a dust collection system. When the signal generated by moving dust particles exceeds a preset threshold an alarm output is generated.

PRACTICAL APPLICATIONS

- ▼ Provides early detection of dust emission leaks where it is critical to safety, maintenance, equipment operation, cost-savings, reducing material loss, plant efficiency (energy-savings), good “housekeeping”, employee welfare, environment, local regulations, etc.
- ▼ The **DustAlarm® ES** is designed for broken bag detection / leaking filter detection in the exhaust ducts of baghouses of various sizes, cartridge collectors, cyclones, and any other dust collector containing filters which may break or wear out. *See example on back page.*
- ▼ Protect blowers from damage.
- ▼ Typical material applications include, but are not limited to: feed and grain, food processing (flour, sugar, etc.), wood dust, cement, fly ash, foundries, mining and minerals, steel, ferrous or non-ferrous metals, silica dust, energy, plastics, pharmaceutical and chemical processing.

OPTIONS

- ▼ Continuous trending version available (**DustTrend™ ES**)
- ▼ Optional Quick-Connect Mounting Kits (*See back page*)
- ▼ Available solid coupling probe extensions to provide up to an additional 24” (610mm) of probe length.
- ▼ 316 Stainless Steel probe standard length up to 20” (508mm). [Customer specified probe lengths from 4.75” to 20”.]

(CSL) Custom Probe Length Measurements

(It is recommended to use a probe length that is 1/3 to 2/3 the diameter [or span] of the duct.)

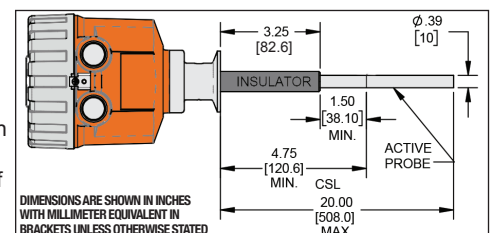



SPECIFICATIONS

Power Requirements:	95-240VAC ($\pm 10\%$), 50/60 Hz; 18-28VDC ($\pm 10\%$)
Power Consumption:	$\leq 5VA$ (AC); $\leq 2.5W$ (DC)
Altitude:	6,562 ft (2000m) max
Installation Category:	II
Pollution Degree:	2
Process Temperature:	Max: 300°F (150°C) at probe location
Starting Ambient Temp.:	4° to 140°F (-20° to 60°C)
Running Ambient Temp.:	-40° to 140°F (-40° to 60°C)
Ambient Humidity:	Max 95% RH, non-condensing
Relay Outputs:	3A @ 250VAC max each (2 Isolated SPDT)
Relay Setpoint:	Factory default: Alarm-1: 5x ref value Alarm-2: 20x ref value
Relay Threshold Range:	1,000,000,000 Max Units
Relay Time Delay:	0 to 60,000 sec (30 sec factory default)
Sensitivity Range:	From 0.0001 grains/ft ³ (0.23 mg/m ³)
Fail-Safe State:	Alarm
Digital Link, Hardware:	RS-485 (3-wire, half duplex, isolated)
Digital Link, Protocol:	Modbus RTU
Running Averaging:	0 to 6,553 sec time constant (100 sec factory default)
Local Indicator:	Bi-color LED: Green On = Power Applied Green Flashing = Auto Setup Red On = Pre-Alarm Red Flashing = Alarm Alternating Red / Green = Error No Light = No Power
Conduit Connections:	(2) 1/2" NPT
Housing:	Powder coated die-cast aluminum; NEMA 4X, ENCLOSURE TYPE 4X, IP66
Mounting:	1" Tri-Clamp Type Quick-Disconnect, 316 SS
Pressure:	40 psi maximum
Insulation Material:	PPS (Ryton®)
Probe Material:	0.39" diameter, 316 Stainless Steel
Probe Length:	Cust. Specified Length - CSL: 4.75" (121mm) to 20" (508mm) [Solid coupling extensions up to 24" (610mm) available]
Approvals / Conformity:	CE Mark
Ship Dims & Weight (Approx):	35.5"Lx8"Wx8"H (902x203x203mm); 7 lbs (3.2kg)

ORDERING INFORMATION

DustAlarm® ES	
Select	Model Series
4	DustAlarm® ES
Select	Configuration
1	Integral Probe / Electronics (Output: Relay and/or RS-485/Modbus)
Select	Probe Type ^{Note 1}
1	Standard Stainless Steel with Ryton® Insulator
Select	Environment / Approvals
1	Ordinary locations
Select	Operating Voltage
1	Universal 24 VDC and 100-240 VAC
Select	Process Connection
1	Tri-Clamp ^{Note 2}

18 - 8 4 1 1 - 1 1 1 Order Number

NOTE:

- The probe length signifies the overall insertion length including the insulator. Required: Please provide specified length (CSL) for probe in inches at the end of the product part #. CSL range is 4.75" minimum to 20" maximum. (Example: 18-8411-111-12 for a 12" specified probe length.)
- Tri-Clamp mounting kits sold separately. Please see "Accessories" section.
- A standard probe is 20" (508mm) maximum in length. Probe extensions are used to extend the standard dust monitor probe. Example: A standard probe ordered with optional Part # 18-0151-0 with a Customer Specified Length (CSL) of 10" will extend the probe by 10 additional inches. The custom length (CSL) must be provided by the customer in addition to the Probe Extension Part #18-0151-0. For example: #18-0151-0, CSL=10". A probe extension will normally be shipped with the device.

ACCESSORIES:

Part #	Description
1-2400	Spanner Wrench, for Cover Removal / Install
18-8007	Kit, Mounting, 1" Ferrule Tri-Clamp (Ferrule, Gasket and Clamp)
18-8009	Kit, Mounting, Convert Tri-Clamp to 3/4" NPT (Threaded Ferrule, Gasket and Clamp)
18-0151-0 ^{Note 3}	Probe Extension, Solid Coupling, Customer Spec Length,

MECHANICALS

DIMENSIONS ARE SHOWN IN INCHES WITH MILLIMETER EQUIVALENT IN BRACKETS UNLESS OTHERWISE STATED

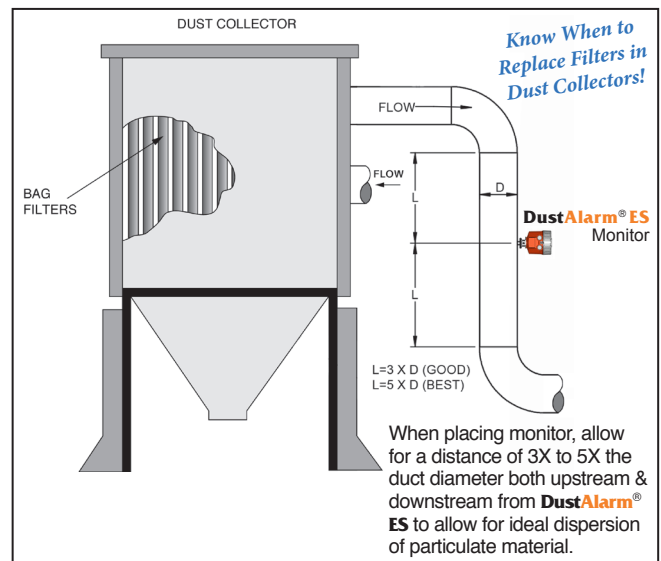
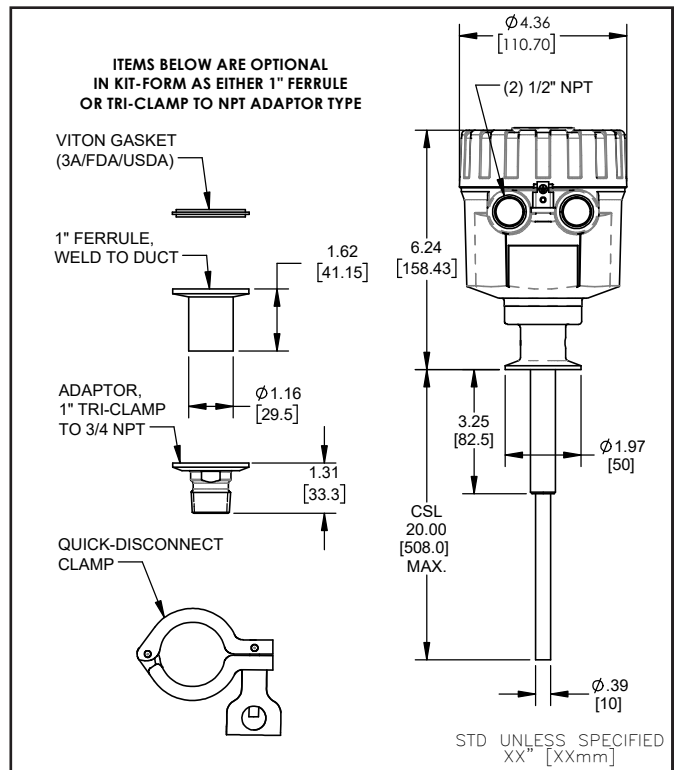

Application Example

Information on this sheet is subject to change without notice

