



Pneumatic Line Magnets

Magnetic Separation For Pneumatic Conveying Lines

TRAMP METAL

FG-06A

Industrial Magnetics, Inc. • 1385 M-75 South • Boyne City, MI 49712 • p: 888.582.0821 • f: 231.582.2704 • w: www.magnetics.com • e: imi@magnetics.com

Bullet® Magnet

- Flow-thru design with aerodynamic stainless steel nose cone to maintain a uniform flow
- Can be installed anywhere in pneumatic line systems operating at or below 15 psi
- Ideal for use ahead of processing equipment and bulk load outs to assure product purity and protect machinery from tramp metal damage
- Helps extend the life of filters and screens
- Cart mounted models available for truck and rail car bulk unloading

The nose cone diverter and magnet assembly of the Bullet® Magnet is designed to maintain a balanced flow through the housing thereby maintaining uniform velocity in line flow. Ideal for dilute phase systems, typical Bullet Magnet applications include: processing of powders, flour, chemical, resin, food stuff, pharmaceutical and mineral materials.

Features: Leak-Resistant Seal, Easy Clean Stripper Collar (Standard on all Rare Earth Models), Door Mounted Magnet (removes magnet from product flow for cleaning) and Stainless Steel Construction.

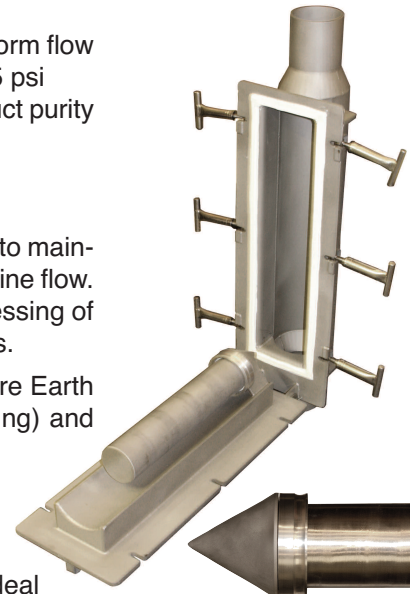

Stripper Collar

Exposed Pole Tube Magnet

• Open flow design is ideal for use where product degradation is a concern • Ideal for use in dense phase systems operating at or below 15 psi

• Typical installations include processing of pelletized plastics, foods, feed and grain or conveying of fibrous products or similar products that may have a high moisture content with a tendency to clog or congeal

• Ideal for use ahead of processing equipment and bulk load outs to assure product purity and protect machinery from tramp metal damage

• Cart mounted models available for truck and rail car bulk unloading

Exposed Pole Tubes have the magnetic portion built into the body of the housing. Ceramic EP tubes are ideal for capturing large tramp metal such as nails, bolts or screws. The Rare Earth version can capture fine particles of metal. Rare Earth EP Tubes feature a door mounted magnet (removes magnet from product flow for cleaning).

Features: Leak-Resistant Seal and Stainless Steel Construction.

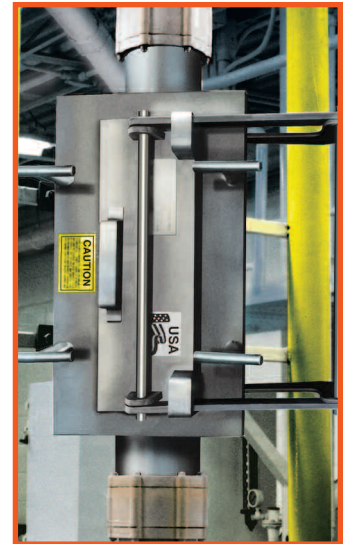

4JIT Vacuum Line Magnet

Ideal for vacuum unloading systems for handling whole beans, grains, pelletized products, plastic resins and granulars from bins, boxes, hoppers and gaylords. The Vacuum 4JIT magnet captures ferrous metal contaminants. The powerful Rare Earth magnet cartridge provides optimum equipment protection and improved product purity without restricting product flow.

Quickly clean captured tramp metal by removing the clamp to separate the two halves. Once separated, the powerful rare earth tube is exposed. With a gloved hand or shop rag, simply wipe the collected metal from the magnet and re-connect the halves. Vacuum 4JIT line magnets are available from 1-1/2" to 2-1/2" line sizes.

Pictured: Top: EZ-Clean Rare Earth Bullet® Magnet, Middle: Rare Earth EP Tube, Bottom: 4JIT Vacuum Line Magnet.



Key Markets

Dense or dilute phase pneumatic conveying of dry or granular products such as food, feed, grain, plastics, chemical

Related Products

Magnetic separation products prior to air lock and after cyclone

Pneumatic Line Magnets

Improve product purity while protecting processing equipment from metal damage.

The aerodynamic nose cone and flow-thru design of IMI's Bullet Magnet allows it to be used anywhere in a pneumatic line system. The Bullet Magnet® is ideal for use ahead of processing equipment and bulk load outs to assure product purity and protect machinery from tramp metal damage.

The nose cone assembly is designed to maintain a balanced flow through the housing thereby maintaining uniform velocity in line flow. Ideal for dilute phase systems, typical Bullet Magnet applications include: processing of powders, flour, chemical, resin, food stuff, pharmaceutical and mineral materials.

- Leak-Resistant Silicon seal (factory tested to 15psi)
- Easy Clean Stripper Collar is standard on Rare Earth models
- Ceramic 8 Magnet Material
- 45 MgOe Rare Earth Magnetic Material
- Negligible pressure drop across magnet
- Gas springs to assist door opening on 6" and 8" models. (except Horizontal Side Mounted Installation)
- Magnet mounted on hinged door to allow removal from product flow when cleaning
- Stainless steel construction for long, non-corrosive life

OPERATION:

The Bullet Magnet is permanently mounted onto a hinged door for easy cleaning accessibility. The magnet has an Easy Clean Stripper Collar that slides off with minimum force. As the sleeve is removed, the captured tramp metal slides off with it, and falls off as soon as it is removed from the magnetic field.

BULLET MAGNET DIMENSIONS:

Dimensions are representative of product at date of publication. If dimensions are critical call for up to date changes and revisions.

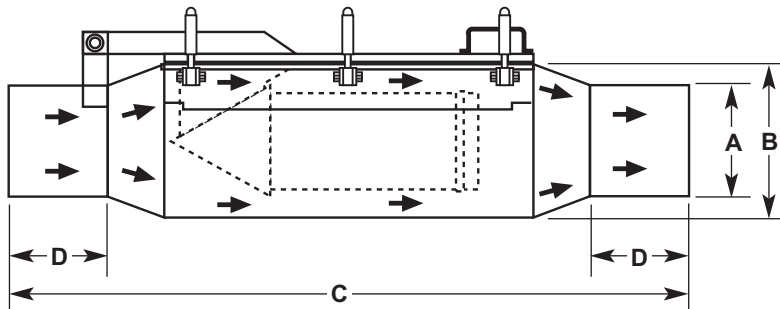

Model	A	B	C	D	E	**F	Wt.
BM3000	3 O.D.	4½ O.D.	36	5½	8	-	95 Lbs.
BM4000	4 O.D.	5½ O.D.	36	5½	8	-	100
BM5000	5 O.D.	6 O.D.	36	5½	*8 or 9	-	105
BM6000	6 O.D.	8½ O.D.	48	6	10.38	26	210
BM8000	8 O.D.	10½ O.D.	48	7	12.38	28	270

NOTE: *The face plate width (E) is 8" on Rare Earth models and 9" on Ceramic units for the BM5000 Magnets.

**The (F) dimension only applies to 6" and 8" O.D. models that have door mounted gas springs.

All dimensions are stated in inches

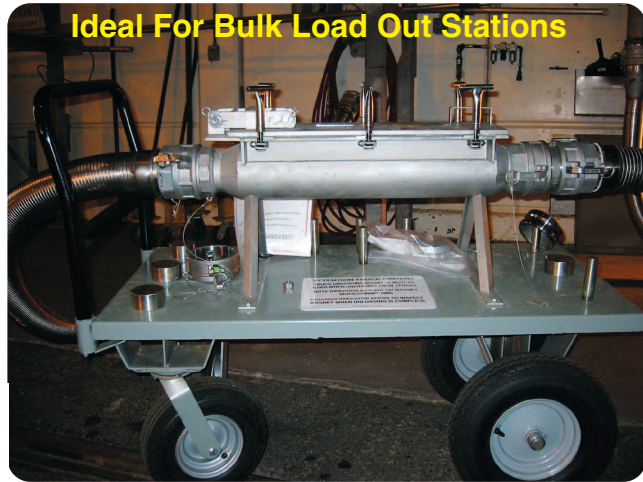

OPTIONS:

- 316L stainless steel construction
- Cart mounting for load-out
- Standard pipe-size ends
- Food grade finish and welds
- Sanitary finish and welds
- EZ Clean Stripper Sleeve
- ANSI bolt pattern flanges
- ANSI spec flanges
- Side mounted hinges
- Custom line sizes
- Couplings
- Camlock fittings

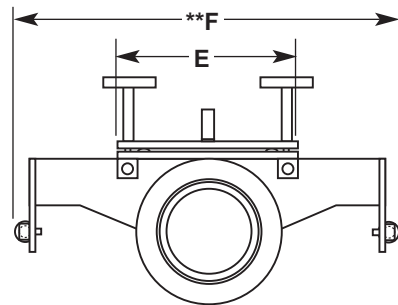
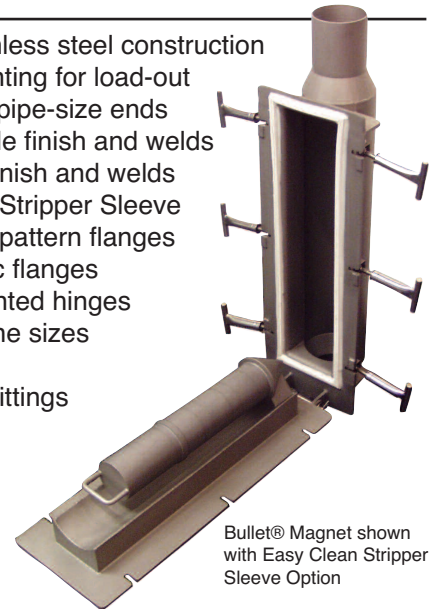

Pneumatic Line Magnets

The flow-through design of IMI's Exposed Pole Tube magnet (EP Tube) makes it ideal for use in pneumatic line systems where degradation is a concern or where the products being conveyed may have a tendency to clog or congeal.

- Provides product purity control and incoming product inspection for bulk loadout docks
- Leak-resistant flat to flat seal for line pressures up to 15 psi
- Lorenz® T-Handle clamps for a positive seal
- 304 Stainless steel housing for long, non-corrosive life
- Rare earth model features door mounted magnet for cleaning off collected metal outside of the flow
- Grade 8 Ceramic Magnets for Ceramic EP Tubes
- 45 MgOe Rare Earth Magnets for Rare Earth EP Tubes



OPERATION:

The EP Tube is available in either Ceramic or Rare Earth designs. Ceramic versions, ideal for capturing large tramp metal such as nails, bolts or screws, have the magnetic portion built into the body of the housing. To clean, open the hinged door, reach into the housing and remove the collected metal.

Rare Earth versions, ideal for capturing fine particles of metal, are designed with the magnet mounted on a hinged door. To clean, unclamp the door, swing it open and away from the product flow and remove the collected metal.

OPTIONS:

- Ceramic or Rare Earth magnet material
- 45 MgOe Rare Earth magnetic material
- Standard pipe-size ends
- Custom line sizes
- ANSI bolt pattern flanges
- ANSI spec flanges
- Food grade finish and welds
- Sanitary finish and welds
- Couplings
- Camlock fittings
- Magnet mounted to cart for portable pneumatic bulk unloading applications

Ceramic Models	O.D.		C	D	C/L E	C/L F	Wt. (Lbs.)
	A	B					
EPT2000C	2	11 $\frac{3}{4}$	36	9 $\frac{1}{2}$	5	11 $\frac{7}{8}$	50
EPT3000C	3	14 $\frac{1}{4}$	36	9 $\frac{1}{2}$	6	11 $\frac{7}{8}$	80
EPT4000C	4	14 $\frac{1}{4}$	36	9 $\frac{1}{2}$	6	11 $\frac{7}{8}$	82
EPT5000C	5	16 $\frac{1}{4}$	39	11	8	11 $\frac{7}{8}$	115
EPT6000C	6	16 $\frac{1}{4}$	39	11	8	11 $\frac{7}{8}$	117
EPT8000C	8	20 $\frac{1}{4}$	50	11	10	22 $\frac{7}{8}$	335

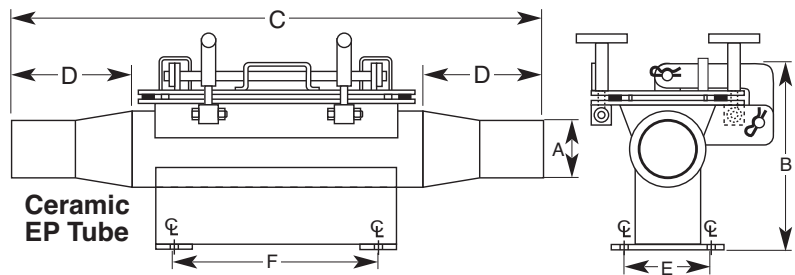

- All dimensions are stated in inches.
- Dimensions are representative of product at date of publication.
- If dimensions are critical, call the factory for up-to-date changes and revisions.

Rare Earth Models	O.D.		C	D	C/L E	C/L F	Face G	Wt. (Lbs.)
	A	B						
EPT2000R	2	6 $\frac{1}{8}$	36	9 $\frac{7}{8}$	6	11 $\frac{7}{8}$	8	45
EPT3000R	3	8 $\frac{1}{16}$	36	9 $\frac{7}{8}$	6	11 $\frac{7}{8}$	8	67
EPT4000R	4	8 $\frac{1}{16}$	36	9 $\frac{7}{8}$	6	11 $\frac{7}{8}$	8 $\frac{3}{4}$	78
EPT5000R	5	9 $\frac{1}{16}$	36	9 $\frac{7}{8}$	8	11 $\frac{7}{8}$	9 $\frac{3}{4}$	91
EPT6000R	6	10 $\frac{1}{16}$	36	9 $\frac{7}{8}$	8	11 $\frac{7}{8}$	10 $\frac{3}{4}$	105
EPT8000R	8	12 $\frac{1}{8}$	48	13 $\frac{3}{8}$	11	22 $\frac{7}{8}$	13	137

The EP Tube is shown here with the door partially open. The magnet is mounted on the door on Rare Earth models & in the housing on Ceramic models.

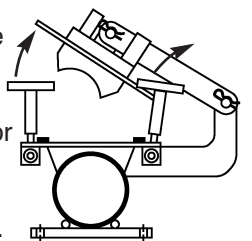

Rare Earth EP Tube

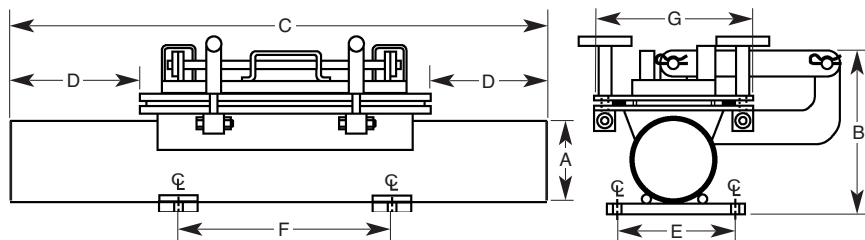

Pneumatic Line Magnets

Magnetic Separation For Pneumatic Conveying Lines

The 4JIT magnet cartridge captures ferrous metal contaminants to provide equipment protection and improved product purity.

Clean captured metal by removing the clamp to separate the two halves. Once separated, wipe the metal off the magnet a gloved hand or shop rag.

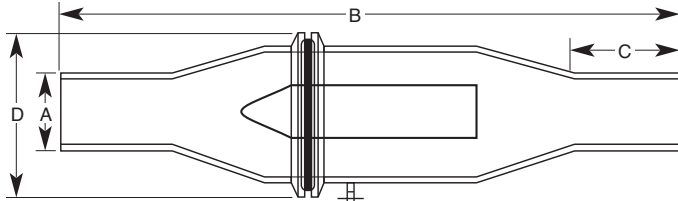

4JIT1500R & 2000R

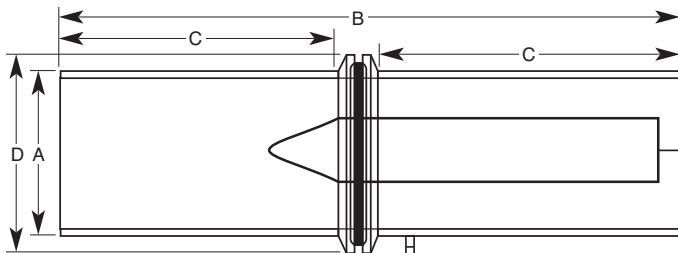

4JIT2500R



OPTIONS:

- Custom sizes and finishes
- Ceramic or Alnico magnetic circuits

FEATURES:

- Welded stainless steel construction
- Powerful Rare Earth UHI-50™ Magnetic Circuit
- Coupling ends are constructed of .065" wall tubing
- One piece, stainless steel clamp
- Viaton, flange matched gasket material for leak-resistant operation

Part Number	Line Size A (O.D.)	Overall Lgth (B)	Coupling Lgth (C)	Overall Dia. (D)	Wt. Lbs.
4JIT1500R	1½"	12⅛"	2⅛"	3⅛"	3.33
4JIT2000R	2"	10⅛"	2⅛"	3⅛"	3.00
4JIT2500R	2½"	6¾"	2⅜"	3⅛"	2.50

Pneumatic-Line Magnet Installation Guidelines

Pneumatic Line Magnets can be installed vertically, horizontally, or at an angle. Vertical Position will allow product to drain from the magnet area when the system is shut down.

For Placement of a pneumatic line magnet near a curve: Magnet should be located 10 times the line diameter away from the curve. *Example:* 10 X 4" line = 40" from curve.

Note: Vertical Mounting is recommended for Ceramic EP-Tubes.

*Horizontal Side Mount (HS)

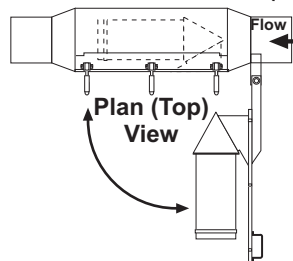

*Horizontal Up Mounted (HU)

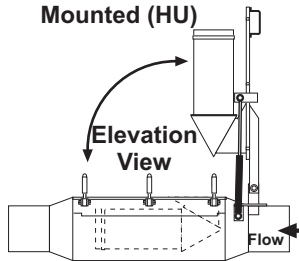

*Horizontal Down Mounted (HD)

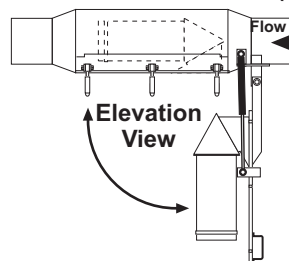

*Vertical Down Mounted (VD)

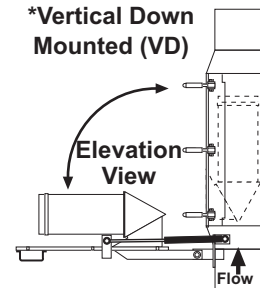

*Modular Door Mounting Kit is available for 6" and larger Bullet® Magnets. The kit allows for on-site installation position changes for Bullet® Magnets ordered for HU, HD and VD mounting styles.