

RECTANGULAR AIR PAD

- ▼ **Promotes Material Flow**
- ▼ **Rugged Construction**
- ▼ **Economical**
- ▼ **Easy Installation**

The Monitor air pad bin aerator is an aeration device used to promote the flow of dry bulk powders from a storage vessel.

PRINCIPLE OF OPERATION

The Air Pad operates by continuously introducing air into the body of the dry powder. When a powder is first conveyed into a storage vessel it is actually a highly aerated mixture of air and particulate. In this state the mixture flows quite readily. However, as the powder settles the solid particulate and air separate resulting in a decrease in volume and an increase in bulk density. In this deaerated state powders can behave more like a single large solid structure rather than a fluid-like mixture. By replacing the naturally lost air, the air to particulate mixture ratio is held thus maintaining the fluid like characteristic of the aerated powder.

APPLICATIONS

For best results in promoting the flow of dry bulk powders, multiple rows of air pad bin aerators should be used. The number of rows and quantity of air pads in each row will differ by application. Monitor application engineers are ready to provide you with the best recommendation for your specific material flow problem.

Generally, four rows of air pad bin aerators on 12 inch (305mm) or 15 inch (381 mm) centers is recommended. While the effective radius of each air pad is approximately 10 inches (254 mm), the air pads should be spaced so that the entire troublesome area is within the sphere of influence of the air pads. The following table should be used to determine the recommended air pads per row.

| 12 in (305 mm) Centers | | 15 in (381 mm) Centers | |
|----------------------------|-------------------|----------------------------|-------------------|
| Length of Sloping Bin Wall | # of Air Pads/Row | Length of Sloping Bin Wall | # of Air Pads/Row |
| 1ft 8in (508mm) | 2 | 1ft 11in (584mm) | 2 |
| 2ft 8in (813mm) | 3 | 3ft 2in (965mm) | 3 |
| 3ft 8in (1,118mm) | 4 | 4ft 5in (1.35m) | 4 |
| 4ft 8in (1.42m) | 5 | 5ft 8in (1.42m) | 5 |
| 5ft 8in (1.73m) | 6 | 6ft 11in (2.1m) | 6 |
| 6ft 8in (2.0m) | 7 | 8ft 2in (2.5m) | 7 |
| 7ft 8in (2.34m) | 8 | 9ft 5in (2.87m) | 8 |
| 8ft 8in (2.64m) | 9 | 10ft 8in (3.25m) | 9 |
| 9ft 8in (2.95m) | 10 | 11ft 11in (3.63m) | 10 |

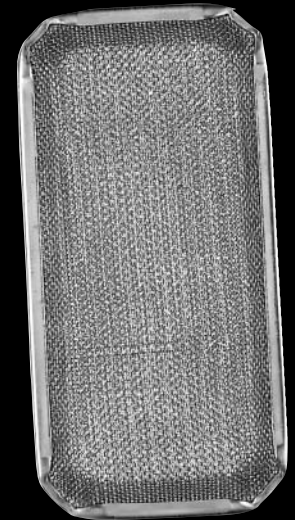

AIR PAD



“SETTING THE STANDARD FOR SUPPLIER EXCELLENCE”

BULLETIN 933 AIR PAD

TYPICAL APPLICATIONS INCLUDE, BUT ARE NOT LIMITED TO:

- ▼ Cement
- ▼ Soda Ash
- ▼ Carbon Black
- ▼ Bentonite
- ▼ Lime
- ▼ Fly Ash
- ▼ Gypsum
- ▼ Flour
- ▼ Resins

FEATURES

- ▼ Effective radius of 10 inches (254 mm)
- ▼ Adapts to almost any bin configuration
- ▼ Low cost
- ▼ Easy installation
- ▼ Minimal maintenance

ACCESSORIES

An external mounting kit is available. This kit can completely eliminate the need to enter the bin to install or service air pad bin aerators. Using a 2-5/8 X 6-5/8 inch (6.7 X 16.8 mm) cutout hole in the bin wall, the mounting kit can be completely installed and serviced from outside the bin. Our air pad and external mounting kit can easily install in existing cutouts of other brands.

The external mounting kit includes gaskets, clamp bracket, rectangular mounting bracket and necessary hardware for mounting with your air pad bin aerator and its mounting hardware. An external mounting kit for high temperature applications is also available.

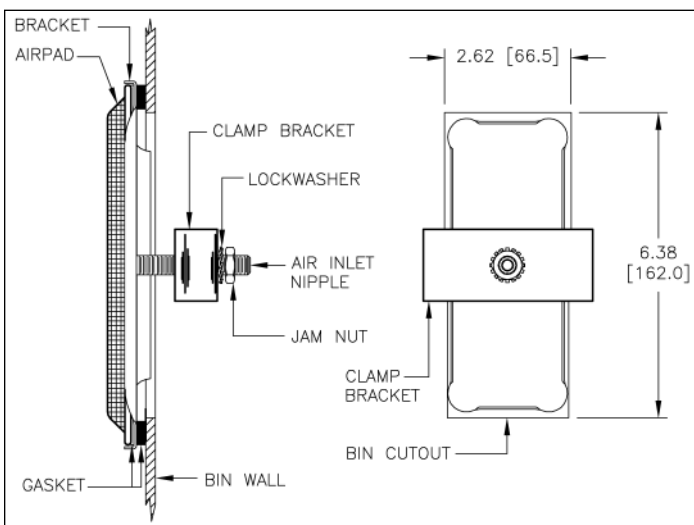

Use of External Mounting Kit

MECHANICALS

DIMENSIONS ARE SHOWN IN INCHES WITH MILLIMETER EQUIVALENT IN BRACKETS

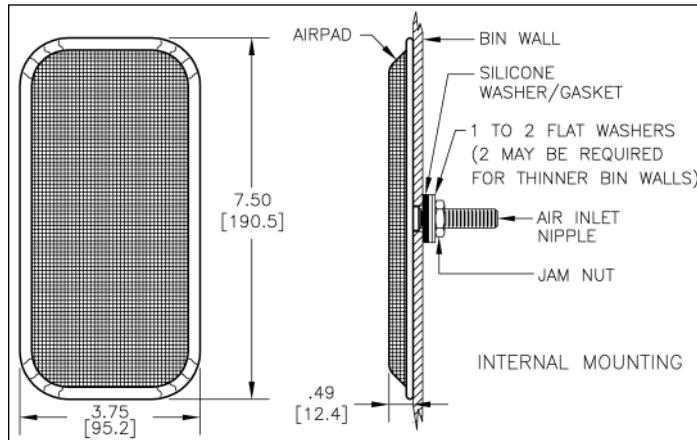

ORDERING INFORMATION

3 - 8 5 X X

CONSTRUCTION
1 = Zinc Plated Steel
2 = Stainless Steel

DIFFUSER MATERIAL
1 = Cotton
2 = Fiberglass

ACCESSORIES

- 3-8010 External Mounting Kit
- 3-8011 External Mounting Kit (High Temp)

REPLACEMENT PARTS

- 3-8001 Replacement Mounting Hardware (Internal Mtg.)
- 3-2001 Replacement Gasket for External Mounting
- 3-2003 Replacement Gasket for External Mounting (High Temp)

SPECIFICATIONS

Air Supply/Consumption:

- Air Supply: Clean, dry air 3 to 5 psi
- Air Consumption: 1 psi - 4.2 scfm (0.07 bar - 1.2 m³/min)
- 2 psi - 5.7 scfm (0.14 bar - 1.6 m³/min)
- 3 psi - 6.5 scfm (0.21 bar - 1.8 m³/min)
- 4 psi - 7.1 scfm (0.28 bar - 2.0 m³/min)
- 5 psi - 7.6 scfm (0.35 bar - 2.2 m³/min)

Materials of Construction:

- Body: Zinc-plated steel or 304 stainless steel
- Diffuser: Cotton (Up to 180°F/82°C)
- Fiberglass (Up to 650°F/343°C)
- Diffuser Screen: 16 mesh zinc-plated steel or 304 SS
- Air Inlet Nipple/Nut: 1/8" NPT nickel-plated brass
- Spacer Washers: Nickel-plated steel
- Washer/Gasket: Silicone (Up to 650°F/343°C)
- External Mounting Kit: Neoprene (Up to 180°F/82°C)
- Gaskets: Up to 300°F/149°C
- High Temp Gasket: Zinc-plated steel
- Brackets/Lockwasher:

WARRANTY

Monitor Technologies warrants each air pad it manufactures to be free from defects in material and workmanship under normal use and service within two (2) years from the date of purchase within North America, and within one (1) year from date of purchase outside of North America. The purchaser must notify Monitor of any defects within the warranty period, return the product intact, and prepay transportation charges. The obligation of Monitor Technologies LLC under this warranty is limited to repair or replacement at its factory. This warranty does not apply to any product which is repaired or altered outside of Monitor Technologies' factory, or which has been subject to misuse, negligence, accident, incorrect wiring by others, or improper installation.