



Suspended Overhead Magnets

Magnetic Separation For Belt Conveyed Products

TRAMP METAL

TG-12A

Industrial Magnetics, Inc. • 1385 MI-75 South • Boyne City, MI 49712 • p: 888.582.0821 • f: 231.582.2704 • w: www.magnetics.com • e: imi@magnetics.com

Introduction to Suspended Magnetic Separators

Suspended magnets are designed for separation of ferrous metal from a variety of over-the-belt conveyor applications. Proven in industries such as Mining, Aggregate, Recycling, Tire Shredding, Foundry, Wood Chip, Pulp & Paper, Power Generation, Construction and Demolition.

Benefits of Suspended Magnetic Separators:

- Protect vital processing equipment from ferrous metal damage
- Improve product purity and quality for high volume belt conveyed products
- Deep reaching magnetic circuits supply superior separation capabilities
- Use prior to a metal detector to achieve maximum separation and system performance capabilities
- Reclaims valuable ferrous metal
- Reduce product liability

Self-Cleaning Permanent Magnets (SMS)

The SMS magnets offer optimum operating efficiency with a continuous cleaning belt to keep the magnet face free of collected metal. The powerful, deep reaching magnetic circuit pulls metal to the face of the magnet where the cleaned belt can remove the metal off the end of the magnet and out of the product flow. The compact design of the SMS makes it ideal for use on portable size reduction equipment.

Suspended Electromagnets (SEMO)

These powerful electromagnets are designed to deliver peak ferrous metal separation performance. The "Deep Reaching" magnetic field is ideal for applications that require increased suspension heights for the magnet or that have a deep product burden.

The Self-Cleaning Suspended Electromagnet offers optimum separation capacity by removing collected metal from the magnet face instantly and discharging it out of the product flow. This continuous cleaning function allows the magnetic circuit to maintain maximum magnetic strength at all times.

Manual Clean SEMOs are best suited for applications with a lower volume of ferrous metal in the product flow or in applications where the system is only run intermittently. The ability to turn the magnet "OFF" makes removing the collected metal easy for the operator.

Manual Clean Permanent Magnets (SPMC)

These magnets are a good economical solution for applications that require a magnet for equipment protection but don't encounter enough ferrous metal in their product flow to justify a self-cleaning magnet.

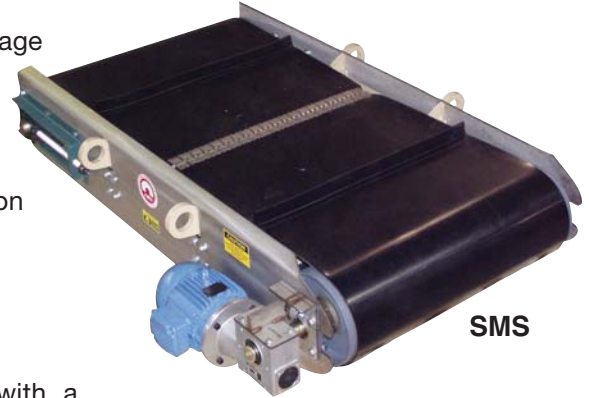

SMS



SEMO (Self Cleaning)



SEMO



SPMC (Optional Swiper Bar Shown)

Key Markets

Mining & Aggregate, Waste Recycling, Pulp & Paper, Foundry

Related Products

Magnetic Separation Pulleys, Drum Separators, EddyCurrent (Aluminum) Separators, Extractors, Vibratory Feeders, M.A.R.S.

All Photos And Drawings Represent The Products At The Time Of Publication (05/09)

Suspended Overhead Magnets

**RARE EARTH
MODELS AVAILABLE
CONTACT FACTORY**

FEATURES:

- Unique magnetic circuit engineered for extended reachout through heavy product burdens
- Low profile design is ideal for portable systems
- Uniform magnetic field across belt width for full coverage
- Extra long field for extended magnetic exposure
- Continuous operation at peak magnetic efficiency
- Stainless steel housing and side guards
- Industrial welded construction
- Four rugged lift lugs for easy suspension
- Pick-up test data is available upon request

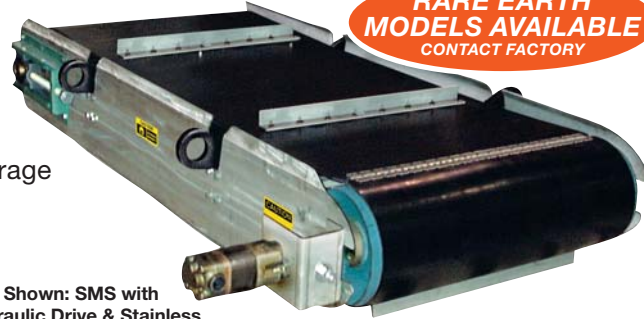

Shown: SMS with Hydraulic Drive & Stainless Steel Cleated Belt (SMS38H2X)

SMS Standard Specifications:

- Ceramic grade 8 magnet material
- Stainless steel magnet box & guards
- 240/480 volt 3 phase motor (Option D)
- 3/8" thick 2 ply rubber belt (Option 1)
- Cross-Belt Application configuration Option X (Std)
- Crowned head & tail pulleys

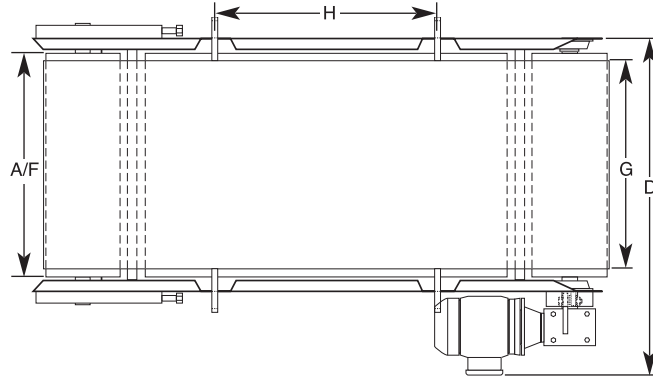

SMS Performance Specifications:

- 26 = 26" wide by 8" thick magnet. Magnet cleaning belt speed is 315 FPM.
- 38 = 38" wide by 10.5" thick magnet. Magnet cleaning belt speed is 380 FPM.
- 44 = 44" wide by 12.5" thick magnet. Magnet cleaning belt speed is 440 FPM.

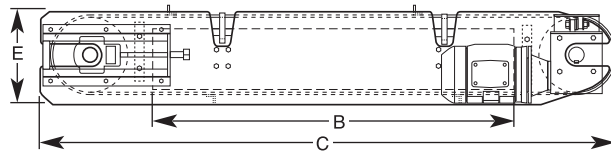

SMS Drive Package Options:

- Option D (Std) - Direct Drive 3 phase motor
- Option H - Direct Drive Hydraulic Motor (8 gpm, 2000 psi)
- Option B - Shaft Mounted Belt Drive

SMS Cleaning Belt Options:

- Option 1 (Std)
220 2 ply Rubber Belt, R2S Flexco Lacing, Vulcanized Cleats
- Option 2
220 2 ply Rubber Belt, R2S Flexco Lacing, 304 Stainless Steel Cleats
- Option 3
Urethane Belt 150 PIW, R2S Flexco Lacing, Vulcanized Cleats
- Option 4
220 2 ply Rubber Belt, R2S Flexco Lacing, 304 Stainless Steel Cleats and Belt Cladding
- Option 5
H.D. 330 3 ply Rubber Belt, R2S Flexco Lacing, 304 Stainless Cleats

Before selecting a magnet let IMI's Tramp Metal Group assess your application and specify the proper solution for your installation.

Model Specifications By Belt Speed (FPM)

Model No.	Magnet Size		Lg.	Wd.	Ht.	Pulley		Belt Width	Lift Lugs Ctr	Motor H.P.	Wt. Lbs.
	A x B	C				D	E				
315 FPM											
SMS2624	26" x 24"	77"	49"	14"	26"	10"	24"	22"	2	1,300	
SMS2630	26" x 30"	77"	49"	14"	26"	10"	24"	22"	2	1,540	
SMS2636	26" x 36"	77"	49"	14"	26"	10"	24"	22"	2	1,770	
SMS2642	26" x 42"	77"	49"	14"	26"	10"	24"	22"	2	2,010	
SMS2648	26" x 48"	95"	49"	14"	26"	10"	24"	40"	2	2,350	
SMS2654	26" x 54"	95"	49"	14"	26"	10"	24"	40"	2	2,590	
SMS2660	26" x 60"	95"	49"	14"	26"	10"	24"	40"	2	2,820	

Model No.	Magnet Size		Lg.	Wd.	Ht.	Pulley		Belt Width	Lift Lugs Ctr	Motor H.P.	Wt. Lbs.
	A x B	C				D	E				
380 FPM											
SMS3824	38" x 24"	77"	56"	14"	38"	12"	36"	22"	3	2,470	
SMS3830	38" x 30"	77"	56"	14"	38"	12"	36"	22"	3	3,030	
SMS3836	38" x 36"	77"	56"	14"	38"	12"	36"	22"	3	3,430	
SMS3842	38" x 42"	77"	56"	14"	38"	12"	36"	22"	3	4,030	
SMS3848	38" x 48"	95"	57"	14"	38"	12"	36"	40"	5	4,680	
SMS3854	38" x 54"	95"	57"	14"	38"	12"	36"	40"	5	5,230	
SMS3860	38" x 60"	95"	57"	14"	38"	12"	36"	40"	5	5,680	

Model No.	Magnet Size		Lg.	Wd.	Ht.	Pulley		Belt Width	Lift Lugs Ctr	Motor H.P.	Wt. Lbs.
	A x B	C				D	E				
440 FPM											
SMS4424	44" x 24"	77"	62"	18"	44"	14"	42"	22"	3	3,250	
SMS4430	44" x 30"	77"	62"	18"	44"	14"	42"	22"	3	3,980	
SMS4436	44" x 36"	77"	62"	18"	44"	14"	42"	22"	3	4,710	
SMS4442	44" x 42"	77"	62"	18"	44"	14"	42"	22"	3	5,440	
SMS4448	44" x 48"	95"	63"	18"	44"	14"	42"	40"	5	6,410	
SMS4454	44" x 54"	95"	63"	18"	44"	14"	42"	40"	5	7,140	
SMS4460	44" x 60"	95"	63"	18"	44"	14"	42"	40"	5	7,870	

SMS Application Type:

- Option I - In-line Applications: The Magnet runs parallel to the conveyor belt and is suspended over the discharge end of the belt.
- Option X (Std) - Cross-Belt Applications: The Magnet runs across the conveyor belt and discharges the collected metal off to the side of the conveyor.

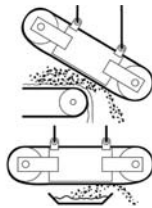

OTHER AVAILABLE OPTIONS:

- 380 volt, 50Hz, 3 phase motor
- Explosion proof motor
- Custom construction and guarding

SPECIAL CONSIDERATIONS: The removal of tramp metal can create many challenges and is dependent upon many factors. These include product size, density, moisture, tramp metal geometry, orientation, entrapment by large product pieces, location in the burden, magnet suspension height and many others.

*Note: Add the appropriate drive package, belt type and application type initials to the end of the Model Number before ordering.
Example: SMS3824D2X is the SMS2438 Magnet with the "Direct Drive" package D, belt package 2 and cross belt X application design.

Suspended Overhead Magnets



Self-Cleaning Electromagnetic Overhead

SEMO(SC) OPERATION:

As the product on a conveyor belt flows under the powerful magnetic field, ferrous material is pulled out of the product flow up to the face of the magnet. With Self-Cleaning models, continuous cleaning of the magnet face is made possible by a heavy duty belt that encircles the magnet on a series of rotating pulleys. As ferrous metal is attracted and held by the magnet, the moving belt carries the collected metal outside of the magnetic field where it is then released beyond the product flow.

SEMO(SC) SPECIFICATIONS:

- Dodge drive components
- 240/480 volt, 3 phase, AC motor
- Shaft mounted belt drive
- Anodized Aluminum coils with Glastic™ Spacers
- Non-combustible coolant
- External expansion tank
- 2" high stainless steel cleats
- Multi-layer industrial grade rubber belting
- Standard industrial bearings and take-ups
- Heavy duty steel channel framework
- Manganese impact plate
- 10 year limited coil warranty

Note: All dimensions are stated in inches.

Model No.	Magnet Dim. A x B	Total Lg. C	Lift Ctr D	Total Wd. E	Pulley Width F	Belt Width G	Total Ht. H	Number of Pulleys	Pulley Dia.	Motor H.P.	Wt. Lbs.
SEMO241SC	24" x 24"	62"	16"	44"	20"	18"	32"	2	16"	2	1,359
SEMO301SC	30" x 30"	75"	22"	51"	26"	24"	32"	2	20"	2	2,206
SEMO361SC	36" x 36"	89"	28"	58"	32"	30"	34"	2	24"	2	3,078
SEMO422SC	42" x 42"	95"	34"	64"	38"	36"	34"	2	24"	3	4,334
SEMO482SC	48" x 48"	93"	40"	69"	44"	42"	38"	4	12"	3	5,982
SEMO542SC	54" x 54"	95"	46"	75"	51"	48"	42"	4	12"	3	7,222
SEMO602SC	60" x 60"	97"	52"	81"	57"	54"	45"	4	12"	5	9,688
SEMO662SC	66" x 66"	103"	58"	87"	63"	60"	48"	4	12"	5	13,560
SEMO722SC	72" x 72"	120"	64"	93"	69"	66"	51"	4	12"	7.5	19,579

*Dimensions represent product at date of publication. If dimensions are critical call for up to date changes. Coolant oillevels must be checked regularly.

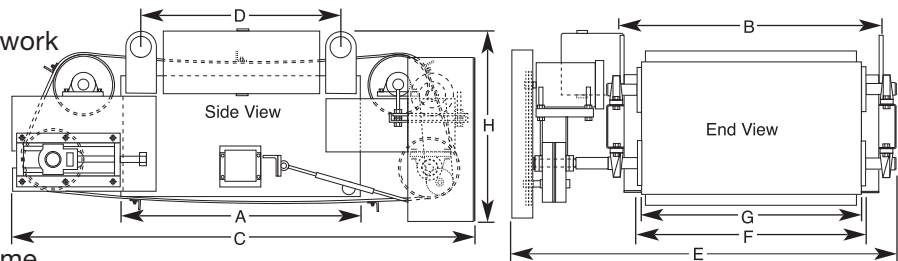

SEMO(SC) OPTIONS:

- Turnbuckles
- Stainless steel clad belt
- Custom steel tube mounting frame
- Permanent plate magnet extensions

Manual Clean Electromagnetic Overhead

MANUAL CLEAN OPERATION:

Ferrous material is pulled out of the product flow and held to the face of the magnet. The collected tramp metal is held in place for as long as the unit has power. To clean the unit, the power source is simply turned off, instantly releasing the metal from the magnet's hold.

SPECIFICATIONS:

- 10 year limited coil warranty
- Non-combustible coolant
- External expansion tank
- Anodized Aluminum coils with Glastic™ Spacers
- Manganese impact plate

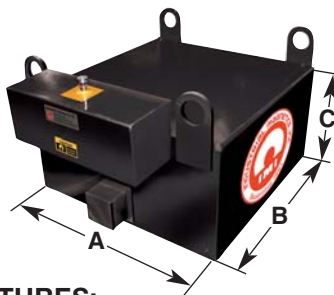

SEMO POWER SUPPLY FEATURES:

- Standard enclosures meet NEMA 4 & 12 specifications
- Input and output fused
- Isolation transformer
- Three phase full wave bridge rectifier
- Transformer overrated for additional protection

Note: Power Supplies are available in VAC single phase and 240/480 and 575 three phase.

SEMO Model No	Required Power Supply	Dimensions H x W x D	Input V 3 Phase	Output Voltage	Supply Watts
241(SC)	PSS43200	24" x 24" x 12"	240VAC	115VDC	2,000
	PSS53200	24" x 24" x 12"	480VAC	115VDC	2,000
301(SC)	PSS43300	24" x 24" x 12"	240VAC	115VDC	3,000
	PSS53300	24" x 24" x 12"	480VAC	115VDC	3,000
361(SC)	PSS43400	24" x 24" x 12"	240VAC	115VDC	4,000
	PSS53400	24" x 24" x 12"	480VAC	115VDC	4,000
422 (SC)	PSS44500	36" x 30" x 16"	240VAC	230VDC	5,000
	PSS54500	36" x 30" x 16"	480VAC	230VDC	5,000
482(SC)	PSS44700	36" x 30" x 16"	240VAC	230VDC	7,000
	PSS54700	36" x 30" x 16"	480VAC	230VDC	7,000
542(SC)	PSS44800	36" x 30" x 16"	240VAC	230VDC	8,000
	PSS54800	36" x 30" x 16"	480VAC	230VDC	8,000
602(SC)	PSS441000	36" x 30" x 16"	240VAC	230VDC	10,000
	PSS541000	36" x 30" x 16"	480VAC	230VDC	10,000
662(SC)	PSS441250	36" x 30" x 16"	240VAC	230VDC	12,500
	PSS541250	36" x 30" x 16"	480VAC	230VDC	12,500
722(SC)	PSS441500	36" x 30" x 16"	240VAC	230VDC	15,000
	PSS541500	36" x 30" x 16"	480VAC	230VDC	15,000

SEMO Model	Magnet Size A x B	Magnet Height C	Magnet Voltage VDC	Magnet Watts	Wt. Lbs.
SEMO241	24" x 24"	14"	115	1,650	974
SEMO301	30" x 30"	16"	115	2,700	1,556
SEMO361	36" x 36"	20"	115	3,800	2,088
SEMO422	42" x 42"	22"	230	5,000	3,284
SEMO482	48" x 48"	24"	230	6,600	4,717
SEMO542	54" x 54"	26"	230	8,000	6,372
SEMO602	60" x 60"	30"	230	10,000	8,278
SEMO662	66" x 66"	32"	230	12,250	11,485
SEMO722	72" x 72"	32"	230	14,500	15,304

Note: All dimensions are stated in inches.*Dimensions represent product at date of publication. If dimensions are critical call for up to date changes. Coolant oillevels must be checked regularly.

Suspended Overhead Magnets

Manual Clean - Permanent Magnet Overheads

BENEFITS:

- Protects Processing Equipment from Ferrous Metal Damage
- Improves Product Purity

DESIGN FEATURES:

- Powerful deep reaching Ceramic 8 magnetic circuit design to penetrate heavy product burdens.
- Uniform magnetic field across belt width for full coverage
- Long magnetic field for extended magnetic exposure
- Continuously operates at peak magnetic efficiency
- No operating cost
- Stainless steel housing
- Four rigid lift lugs for easy suspension
- All welded construction

OPTIONAL FEATURES:

- EZ-Clean swiper bar
- Stainless steel (roller guided) slider plate design for easy removal of collected metal
- Hand crank stainless steel slider with rack & pinion for even easier cleaning
- Custom features available upon request



Shown with EZ-Clean Swiper Bar

SPMC10: (Suspension Height - 8" to 10")

- High strength magnetic separator for typical over the belt applications
- Ideal for low profile burden depths

SPMC12: (Suspension Height - 10" to 12")

- High strength magnetic separator for typical over the belt applications
- Meets or exceeds typical product burdens and magnet suspension height requirements

SPMC14: (Suspension Height - 12" to 14")

- Super strength magnetic separator for over the conveyor separation applications that have above average burden depths & magnet suspension height requirements
- This circuit is designed for applications that require more magnetic pulling force or deeper reachout

SPMC10 Models	Overall Dimensions		Magnet Dimensions			Lift Lug Dimensions		Weight Lbs
	A	A1	B	B1	B2	C	C1	
SPMC10-12	12	26	9	23	8.1	3	17	550
SPMC10-18	18	26	15	23	8.1	9	17	625
SPMC10-24	24	26	21	23	8.1	15	17	825
SPMC10-30	30	26	27	23	8.1	21	17	1,025
SPMC10-36	36	26	33	23	8.1	27	17	1,250
SPMC10-42	42	26	39	23	8.1	33	17	1,440
SPMC10-48	48	26	45	23	8.1	39	17	1,650
SPMC10-54	54	26	51	23	8.1	45	17	1,850

SPMC12 Models	Overall Dimensions		Magnet Dimensions			Lift Lug Dimensions		Weight Lbs.
	A	A1	B	B1	B2	C	C1	
SPMC12-18	18	33	15	30	10.6	9	24	900
SPMC12-24	24	33	21	30	10.6	15	24	1,200
SPMC12-30	30	33	27	30	10.6	21	24	1,500
SPMC12-36	36	33	33	30	10.6	27	24	1,850
SPMC12-42	42	33	39	30	10.6	33	24	2,200
SPMC12-48	48	33	45	30	10.6	39	24	2,500
SPMC12-54	54	33	51	30	10.6	45	24	2,800
SPMC12-60	60	33	57	30	10.6	51	24	3,150
SPMC12-66	66	33	63	30	10.6	57	24	3,500

SPMC14 Models	Overall Dimensions		Magnet Dimensions			Lift Lug Dimensions		Weight Lbs.
	A	A1	B	B1	B2	C	C1	
SPMC14-24	24	51	21	48	12.6	12	42	2,200
SPMC14-30	30	51	27	48	12.6	21	42	2,800
SPMC14-36	36	51	33	48	12.6	27	42	3,400
SPMC14-42	42	51	39	48	12.6	33	42	4,000
SPMC14-48	48	51	45	48	12.6	39	42	4,600
SPMC14-54	54	51	51	48	12.6	45	42	5,200
SPMC14-60	60	51	57	48	12.6	51	42	5,800

Note: All dimensions stated are in inches.

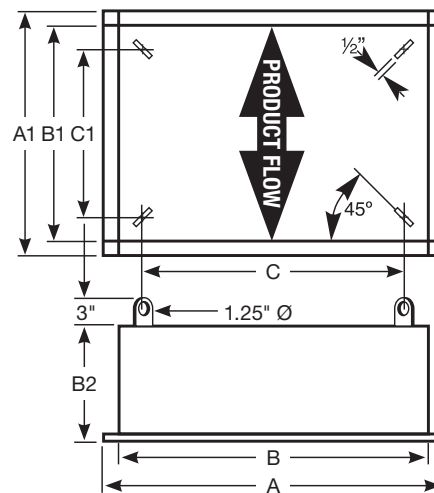

When determining Magnet size, the overall width of the Magnet (A) should be equal to the width of your Conveyor Belt.