



Plate Style Magnetic Separators

Plate Magnets For Angled Chute Applications

TRAMP METAL

TG-01A

IMI's high intensity plate magnets feature durable welded stainless steel construction and heavy duty hinges for easy cleaning.

Flush Face (FF) Plate Magnets are designed for **above-the-flow** applications. The Flush Face model is available in Ceramic and Rare Earth designs to lift ferrous metal out of the product flow, protecting downstream processing equipment and product purity.

Exposed Pole (EP) Plate Magnets are designed for **below-the-flow** applications. The two 400 series (magnetic stainless steel) exposed poles provide added protection from wash-off without impeding the product flow. Exposed Pole models are ideal for low volume chute installations with either Ceramic or Rare Earth magnetic circuits.

Spout Style (SM) Plate Magnets feature a diverter to provide maximum tramp metal separation and superior wash-off protection for high volume **below-the-flow** applications. The diverter protects collected metal from being washed back into the product flow while preventing product degradation. Several strengths are available in Ceramic and Rare Earth designs to meet the requirements of difficult applications.

Magnet Materials for Plate Magnets:

Ceramic: Used for small to larger ferrous particle separation such as nails, bolts, washers, etc that can cause damage to processing equipment.

Rare Earth: Extremely powerful magnet is used for "fine particle" separation such as metal filings, shavings, metal wear residue, work hardened stainless steel, etc. as well as capturing larger tramp metal.

Hump Magnets (Plate-In-Chute Separators) - IMI plate magnets can be provided with engineered chutes to fit directly into your processing lines. Customer specified inlet and outlet requirements can be accommodated using custom designed housings, transitions (round or rectangular), flanges and more. Housings and chutes are available for single plate magnets, multiple plate magnets and for Manual, EZ or Self-Cleaning models. **See Hump Magnet techsheet TG-01B.**

Granulator Plate Magnet (GPM) Protect your regrind operation from tramp metal contamination with IMI's powerful Granulator Plate Magnets. These magnets are designed for easy installation in your granulator's feed tray, and are an economical way to prevent tramp metal from damaging your equipment and contaminating your product.

OPTIONS:

- Ceramic, Grade 8 Magnet Material
- Rare Earth, 45 MgOe Magnet Material
- Custom designs and mounting
- Clamping, lifting and counterweight devices
- Food Grade Finish
- Wear treatment
- Filled space between poles (EP models only)
- EZ-Clean or Self-Cleaning models available

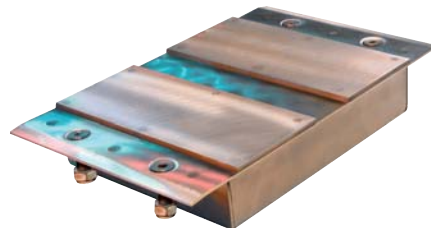

Granulator Plate Magnet (GPM)
• Ideal for Granulator Feed Trays.



Flush Face (FF)
• For above-the-flow applications

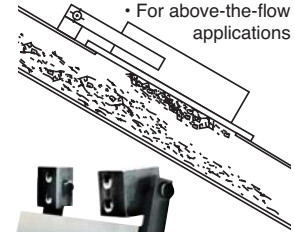

Exposed Pole (EP)
• Typical below-the-flow exposed pole application.

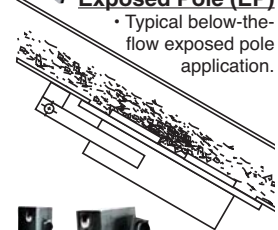

Spout Magnet (SM)
• Ideal for below-the-flow applications.

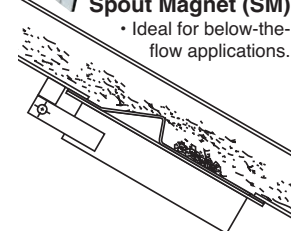

Key Markets

Magnets for Unimpeded Product Flows or dry to slight moisture content; i.e. powders, granular, leafy, etc...

Related Products

Hump Magnets, Inline Separators, Extractor Magnets, Split-Flow Magnets

Plate Style Magnetic Separators

Drawings and Specifications For Plate Magnets

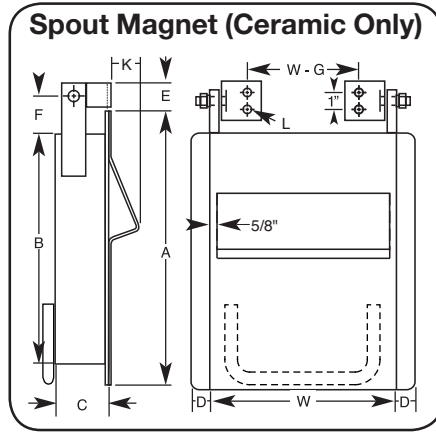
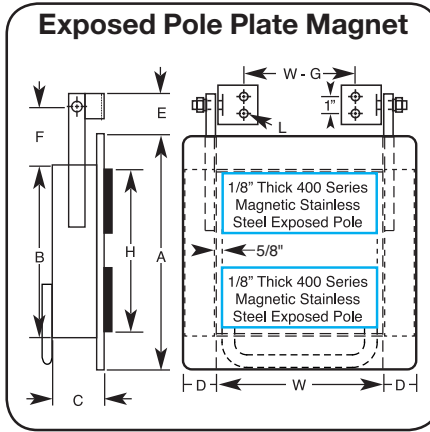
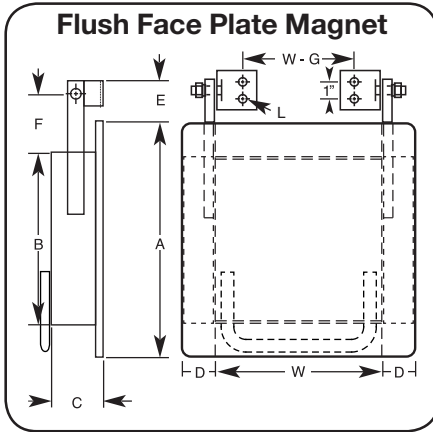

OPTIMUM CHUTE INSTALLATION

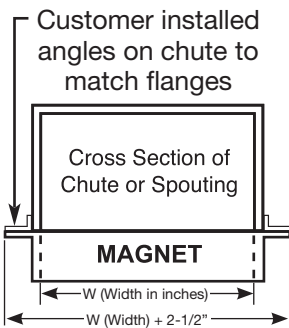

REACH-OUT	MAGNET CAPACITY
Ceramic	
2"	Magnet Width (W) x 166.75 = CF/H
6"	Magnet Width (W) x 500.00 = CF/H
8"	Magnet Width (W) x 667.00 = CF/H
Rare Earth	
3"	Magnet Width (W) x 287.50 = CF/H
5"	Magnet Width (W) x 450.00 = CF/H

CF/H x 0.02832 = Capacity in Cubic Meters Per Hour

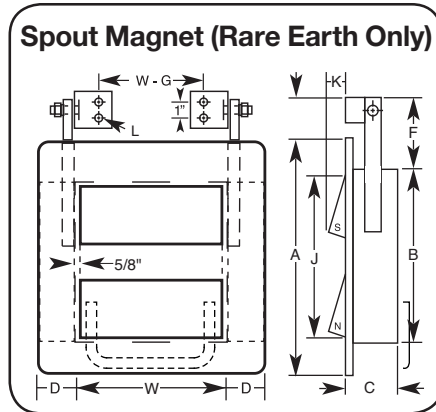

Ceramic Plate Magnet Dimensions

Flush Face	Exposed Pole	Spout Magnet	Reach-Out (In.)	Dimensions (Inches)								EP Only	SM Only	Approx. Wt. Per Inch of Width(W)
				A	B	C	D	E	F	G	H			
FF	EP	SM	2	8.5	6.5	1.38	1.0	1.19	1.81	3.75	6	0.75	0.25	2.0 Lbs./In.
FF	EP	SM	6	14.5	12.5	4.12	1.0	2.75	2.75	4.5	12	1.25	0.5	8.0 Lbs./In.
FF	EP	SM	8	19.5	17.5	8.12	1.0	2.75	2.75	4.5	17	1.25	0.5	24.2 Lbs./In.

Rare Earth Plate Magnet Dimensions

Flush Face	Exposed Pole	Spout Magnet	Reach-Out (In.)	Dimensions (Inches)								EP Only	SM Only	Approx. Wt. Per Inch of Width(W)	
				A	B	C	D	E	F	G	H				J
FF	EP	SM	3	7.5	5.5	1.56	1.0	1.19	1.81	3.75	5	5	0.5	0.25	1.5 Lbs./In.
FF	EP	SM	5	12.5	10.5	2.31	1.0	1.19	1.69	4.5	10	8.75	1.25	0.5	3.4 Lbs./In.

Notes:

1. Plate Magnets with 8" Reach-out have lift lugs on the back of the magnet for handling.
2. Plate magnets are accepted by Mill Mutual Insurance.
3. Magnets with 2" & 3" Reach-Out have hinges with a single hole.

Plate Magnet Ordering Guide Example: EPC06-12

Type of Magnet Face Plate → E
 Magnet Material: (C) Ceramic or (R) Rare Earth → P
 Effective Magnet Reach-out → 06
 Width of Magnet/Chute I.D. in inches → 12

Granulator Plate Magnets (Ceramic Magnet Material Only)

FEATURES:

- Protect your regrind operation from damaging tramp metal
- Designed for installation in the granulator's feed tray
- Low profile design for smooth flow over the magnet face
- Mounts with provided 4-20 stainless steel bolts and lock nuts
- Stainless steel housing with 400 series stainless steel magnetic poles

INSTALLATION:

1. Cut an opening in your feed tray
2. Set the magnet in the opening in the feed tray and mark the location of the mounting holes
3. Remove the magnet and drill the four mounting holes into the feed tray
4. Set the magnet into the opening, insert the bolts into the mounting holes, thread & tighten the nuts onto the bolts

Model No.	Overall Width (A)	Magnet Width (B)	Magnet Length (C)
GPM0550	5.50"	5.10"	6.25"
GPM0750	7.50"	7.10"	6.25"
GPM0950	9.50"	9.2"	6.25"
GPM1150	11.50"	11.10"	6.25"
GPM1300	13.00"	12.60"	6.25"
GPM1500	15.00"	14.60"	6.25"
GPM1700	17.00"	16.60"	6.25"
GPM1900	19.00"	18.60"	6.25"
GPM2100	21.00"	20.60"	6.25"
GPM2300	23.00"	22.60"	6.25"

