

Fox Solids Conveying Eductors

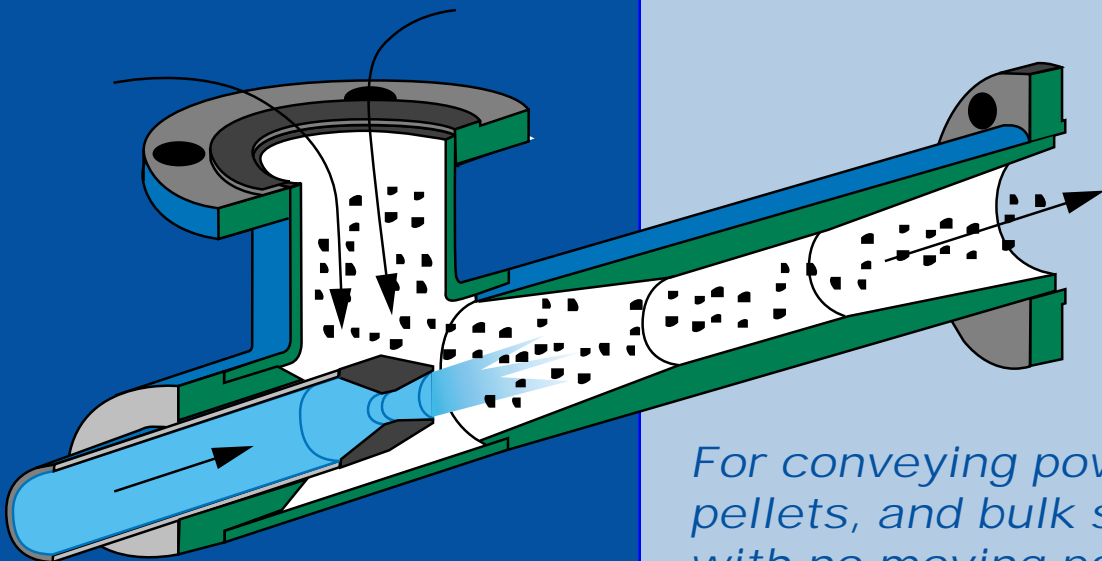

*For conveying powders,
pellets, and bulk solids,
with no moving parts...
Since 1963*



*Bulletin 301D-a
Abridged for Website
Downloading*

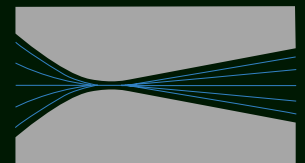

FOX VALVE
DEVELOPMENT CORP
Hamilton Business Park
Dover, NJ 07801
973.328.1011
Fax 973.328.3651
email: info@foxvalve.com
Website: www.foxvalve.com

Fox Venturi Eductors for Conveying Solids with No Moving Parts

- **No Maintenance**
- **No Blow-Back**
- **Minimal Product Degradation**

Fox Venturi Eductors - What are they?

Fox Venturi Eductors convert the output of a blower into a 'vacuum' that can be used to entrain and feed powders, pellets, and bulk solids into a pneumatic conveying system. Because they have no moving parts, they can operate entirely maintenance-free.

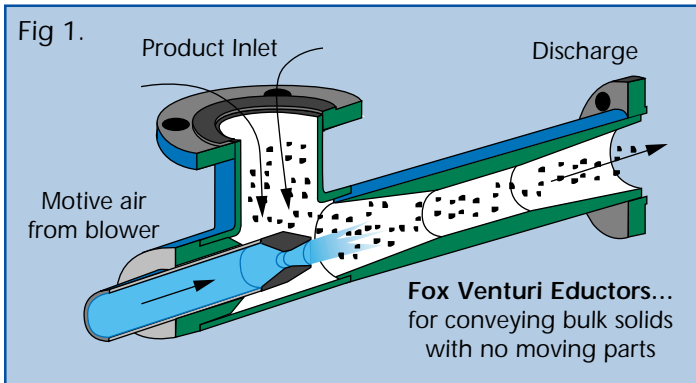

The eductor acts to compress the air/solids mixture to a pressure adequate to overcome losses in the downstream convey line. The eductor has three connections:

- Motive Air
- Suction or Product Inlet
- Discharge

How are they used in pneumatic conveying systems?

Fox Venturi Eductors are used to feed bulk solids, such as powders, pellets, flakes, and particulates, into positive, dilute-phase conveying systems. They are commonly used in place of rotary valves where airlocks simply cannot perform adequately.

Fox eductors are attractive to install beneath other solids processing equipment because, by creating suction at the product inlet, they enable dust-free material conveying systems. They are commonly installed beneath:

- Baghouses/Dust Collectors
- Volumetric and Loss-in-Weight Screw Feeders
- Screener/Classifier Outlets
- Mixers, Grinders, and Mills
- Bins, Silos, and Bulk-bag unloaders

Who uses them?

Fox Venturi Eductors are used in industries as diverse as plastics, power, chemicals, food & dairy, foundries, mining, bakeries, smelting— anywhere that powders or pelletized products are transported. Fox has made installations in hundreds of plants, in dozens of countries, since 1966. Request our database of all existing installations for our most recently updated list.

Why are eductors used in pneumatic conveying systems?

- **Fox Venturi Eductors have no moving parts** - allowing for maintenance-free feeding of bulk solids. In applications involving fine, abrasive, or irregularly-shaped products, this is an enormous advantage. Replacement of existing rotary airlocks with venturi eductors makes for simpler, more reliable conveying systems. Designing with eductors from the beginning ensures the most reliable product feeding available.

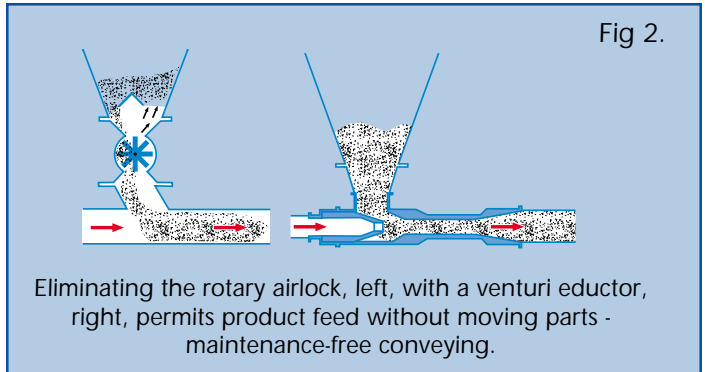

- **No Blowback** - All rotary airlocks have blowback. If the product conveyed is fine or abrasive, blowback can cause extreme wear problems. Even with free-flowing products, blowback can be a problem, causing bridging and housekeeping problems, or even an explosion hazard. When installed beneath baghouses, screw conveyors, or dust collectors, airlocks can be a major source of fugitive dust emissions, which are eliminated after a retrofit to Fox eductors.
- **No mechanical shearing** - Eductors have none of the shearing, smearing or degradation of product common with rotary airlocks. And, of course, safety is simply not a concern with Fox eductors.

How are they designed? How are they tested? Are they guaranteed to work?

Fox's eductor designs have been exhaustively tested with different materials, line lengths, motive air flows and pressures - yielding the most complete set of performance data ever accumulated. This data has been transformed into computer algorithms which allow our engineers to rapidly and precisely predict eductor performance with almost any product in your system.

For a quotation - just complete the Application Data Sheet on Page 11 and fax to Fox!

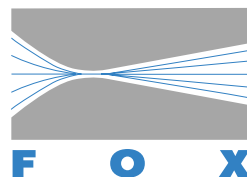

Fox Venturi Eductors

Dover NJ USA

Voice - 973 328 1011, Fax - 3651

info@foxvalve.com

The Ten Most Commonly Asked Questions About Fox Venturi Eductors

1) Don't they need evenly metered feed or they'll clog? Wouldn't a full 'head' of product 'overfeed' the eductor?

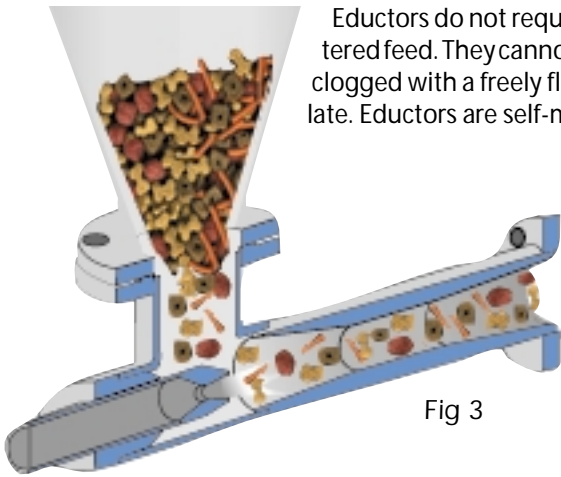

Eductors do not require evenly metered feed. They cannot be overfed or clogged with a freely flowing particulate. Eductors are self-metering.

Fig 3

2) Don't eductors need compressed air to work?

No. 98% of all Fox eductors we sell use air at below 12 psig, with about half of them using air at below 4 psig. See Page 10.

3) Why Fox? Other companies claim they can make venturi eductors for conveying solids. What does Fox know that others don't?

A very great deal. Fox is the only company that sponsored a full-fledged, two year research effort that included hundreds of empirical flow tests with many different products, ranging in bulk densities from 5 to 150 lbs/ft³ conveyed over distances from 50 ft to 200 ft. This data was then collated into algorithms for quickly predicting eductor performance for any pipe geometry with any powder. Couple this with the 3500 or so applications we have sold to industry since 1963, and we think we have a pretty good knowledge base to work with.

4) What conveying velocity does Fox design around? What controls velocity?

The same as any other pneumatic conveying system: 3500 to 4500 ft/min is usually OK for most materials. Fragile products can be conveyed slower; cohesive products should be conveyed faster. Fox eductor systems can easily include features to allow users to easily adjust/minimize convey velocity as required. Each Fox eductor is carefully machined to match the Fox-supplied blower and to pass the right amount of conveying air.

5) If venturi eductors are so great at conveying reliably with no moving parts, how come the big system designers almost never include them, where appropriate, in the large plants they design?

If the most profitable part of your business was selling rotary airlock spare parts, would you introduce your customers to venturi eductors that just keep working on and on and on?

6) Is there a simple "Rule of Thumb" we can use to predict how much air we need? No. Too many factors are involved in the design of a pneumatic conveying system. To get the right answer as to how much motive air is required, just complete a standard Application Data Sheet and fax to Fox. You'll usually get an answer in one day.

7) Can we have our material tested? Can we witness these tests? Can you run degradation trials?

Yes to all. Most products already appear on our list of 3500 existing installations, so we do not normally need to run tests to predict flow rates and blower sizing. (See Fox test rig at right.) Predicting degradation with fragile products often does require testing.



8) We need to convey very hot materials. What temperatures can eductors handle?

A plain old 316 ss eductor can work happily at 1100 - 1200° F. For temps up to 1600°, we'd just build it in Inconel.

9) How does an eductor meter or control the feed rate?

It does not. Eductors cannot be used to regulate convey rates. They have a maximum capacity or rating for a given product in a given system, but do not control rates. If you must have accurate flow control of the solids, you need to use a vibratory, or screw feeder (as shown below) or other device to dose rate. Fox often integrates this equipment together into an engineered, single-source solution.

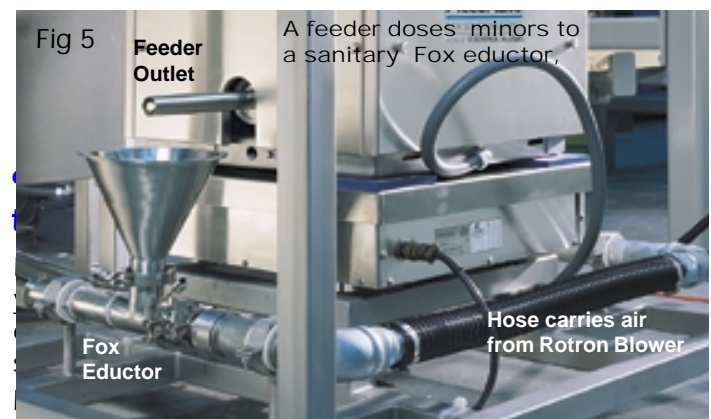

10) How fast can we get them?"

Fox has a large range of standard eductors ranging from 1" to 6" size, in ss, cs, and ceramic-lined that can all ship in one week. Blowers can ship in 2 - 3 days (Rotron blowers) to 3 - 6 weeks (for pd blower packages.) Expediting is always an option.

That's all very interesting....

But Can Venturi Eductors Convey **MY Product?**

Let's Start with the letter :

Fox maintains an up-to-date database of all installations made with Fox venturi eductors: about 3500 listings in mid - 2004. Below is a partial list of only those products conveyed beginning with the letter "A." Note that each individual listing, such as 'activated carbon' could actually represent as many as 200 individual installations. Please have us check our database to see if we have conveyed your product!

Abrasive/ Blast Grit
Absorbent, SAP polymer
AC Base
Acid Pellets
Acid Powder, Organic"
Acrawax
Acrylic Acid/Copolymer
Acrylic Flake
Act Carb +Hy'd Lime
Activated Carbon
Activated Charcoal
Additive
Adhesive, Dry
Adipic Acid
Adipic Acid Fines
Aerogel
Aerosil
Aggregate/gravel
Aggregate Dust
Alamin
Alginate
Almond Chips
Almond Meal
Almonds
Alum Salt
Alum, Spent (ALOH)
Alumina
Alumina Brick,
Alumina Catalyst
Alumina Dust
Alumina Granules
Alumina Hydrate
Alumina Monohydrate
Alumina Powder

Alumina Silica Powder
Alumina Silicate
Alumina Slugs
Alumina Sulfate
Alumina Trihydrate
Alumina/Cerium Powder
Aluminium Chips
Aluminum Oxide
Aluminum, Shredded
Aluminum + Plastic flakes
Aluminum Chloride
Aluminum Chlorohydrate
Aluminum Dioxide
Aluminum Dross
Aluminum Flakes
Aluminum Foil trim
Aluminum Hydrate
Aluminum Oxide
Aluminum Oxide Grit
Aluminum Pellets
Aluminum Powder
Aluminum Silicate
Aluminum Strips
Aluminum Wire, Chopped"
Amersorb
Ammonium Bicarbonate
Ammonium Bichromate
Ammonium Chloride
Ammonium Sulfate
Ammonium Triosulfate
Anamol Oxide
Anthracite
Anthracite Fines
Anticaking Agent

A

Anti-perspirant Powder
Apple Bits
Apple Bits + Almonds
Apple Crumblets
Artificial Sweetener
Asbestos Fines
Ascorbic Acid
Ash
Ash & Limestone
Ash, Film w/silver at 600°F
Ash Flyash
Ash + Cement
Ash, Flyash at 300°F
Ash Conditioner Additive
Ash, Boiler
Ash, Bottom
Ash, Filter
Ash, Pyrolyzed
Ash, Rice Hull
Aspartic Acid
Atrazine
Attapulgate Clay, Processed

Please request that we fax you a page from our database that lists YOUR product!

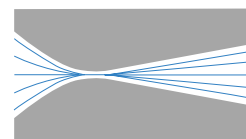

F O X
Fox Venturi Eductors

Dover NJ USA

Voice - 973 328 1011, Fax - 3651
info@foxvalve.com

Where Does MY Industry Use Fox Eductors?

Although we have sold Fox eductors for use into just about every industry that requires bulk solids handling, we can list a handful of industries here where Fox eductors have been used for decades,

in many, many installations. We also list relevant Case Studies which you can request, and which describe specific applications within this industry:

Building Products: *Conveying:* Phenolic resin and sawdust for chipboard; Gypsum for sheetrock; Pumice powder for grout; Roofing granules;

Cement: *Conveying:* CKD at up to 800° F; Portland cement at up to 20,000 lbs/hr; Alternate fuel injection (shredded carpets/plastic/tires/paper; biomass, rice hulls.) Kiln spill at 1600° F

Ceramics/Glass: *Conveying:* Silica, Glass Frit, Ceramic pellets, Ceramic dust, Mica

Environmental: *Conveying:* Activated Carbon, Sodium Bicarbonate, Hydrated Lime, Pulverized Limestone into ducts and stacks; Sorbent injection in fluidized bed boilers for SOx reduction,

Food: *Conveying:* Minor ingredients to mixing/batching (salt, sugar, spices, vitamins, flavorings, etc.); Milk powders from spray dryers; Coffee beans from bulk bags; Powdered tea from screeners; Rice; Breakfast cereal from coating reels; Snack food extrudate from extruders; Frozen peas from IQF; Whole peanuts from sorters;

Foundries: *Conveying:* Foundry dust from dust collectors; Inoculant to cupolas; Metal grit from grinding stations; Sand and bond

Hygienic/Diapers: *Conveying:* SAP from feeders with uniform flow distribution

Minerals/Mines: *Conveying:* Hot copper and nickel alloys at 1000° F from calciners; Mica, talc, quartz, and perlite ore from dust collectors; Copper pellets at 400 lbs/ft³ bulk density;

Plastics: *Conveying:* Plastic pellets with reduced angelhair and fines from hundreds of extruders and compounding lines since 1963; 50+ fiberglass filled pellets with Clean-in-place, ceramic-lined wear resistant eductors; Conveying plastic regrind and flakes that jam airlocks in 10 minutes;

Power/Incineration *Conveying:* Coal, coke, and alternative fuels; Additives for inhibiting slag build-up on boiler tubes; sorbents for SOx reduction in CFB's; Activated carbon, lime, calcium carbonate, Trona injection for flue gas desulfurization (FGD)

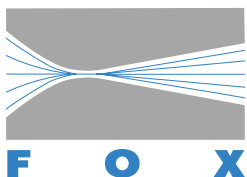

Fox Venturi Eductors
Dover NJ USA
info@foxvalve.com

How To Use Eductors in a Pneumatic Conveying System

Designing New Systems with Venturi Eductors:

As with any conveying system, the three basic questions are: What product? How much? How far? Send us a completed data sheet and Fox engineers will prepare a **Performance-Guaranteed** quotation on an eductor or a complete conveying system. The quotation will include all relevant operating data.

Limitations:

- for Rates up to 15 - 20,000 lbs/hr
- for Distances up to 300 ft

Fox Venturi Eductors can convey most dry bulk solids, but the following conditions must be met:

- Solids must be gravity fed into the eductor.
- Downstream piping can never be reduced.
- Eductors can never be used in series.
- All elbows should be wide-radius. Flex hose lengths must be under 5 - 10 ft.
- Conveying line length must be below 400 ft.
- Adequate venting/dust collection at destination.
- Eductors are almost never used for truck, barge, or railcar unloading.

Retrofitting Existing Equipment

Retrofitting existing systems with Fox eductors can result in very significant improvements. These may include:

- **Eliminate airlock wear**
- **Reduce product damage/degradation**
- **Avoid dust emissions and leakage**
- **Facilitate clean-outs if cross-contamination is critical**
- **Reclaim otherwise discarded product**

Please note that retrofitting existing pneumatic conveying systems with eductors can have some technical and commercial challenges:

- Technical - Airlocks may experience wear and excessive blowback when the downstream convey line and/or blower is undersized for the given application. A simple replacement of the airlock with an eductor in this circumstance is possible, but unlikely.
- Commercial - In order to successfully retrofit an existing system, Fox would need to analyze and understand the existing blower, existing pipe geometry, existing dust collection, characterize the material to be conveyed and understand the rate requirement. Fox cannot then guarantee the operation of the entire system if our Scope of Supply is limited to just a replacement venturi eductor.

Retrofitting Dust Collectors and Baghouses with Fox Eductors

Eductors are frequently installed beneath dust collectors, often replacing screw conveyors which collect dust from multiple outlets. Screw conveyors are primary sources of fugitive dust, often need repair, and require that all modules of a baghouse be shut down if one outlet is clogged or need repair. Multiple eductors enable all outlets to operate while one is accessed for maintenance.

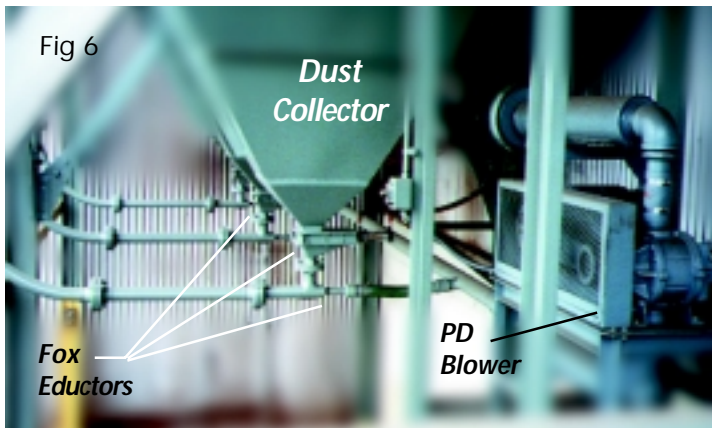

Fig 6
A single positive displacement blower is used to drive three 2" Fox Eductors located beneath a three-cell collector at a foundry.

How Much of the Conveying System Can Fox Provide?

Blowers

All eductors require a source of conveying air, which is typically supplied by a blower at below 14 psig. Every year, Fox supplies hundreds of Educator/Blower subsystems, providing a perfectly matched blower to the required educator. (For more info on these sub-systems, **Request Bulletin 302**) Any type, or make of blower can be provided but most fall into the following two categories:

- **Rotron blowers** – output to 6 psig.
- **Positive Displacement blowers** -- to 15 psig.

Fig 8.

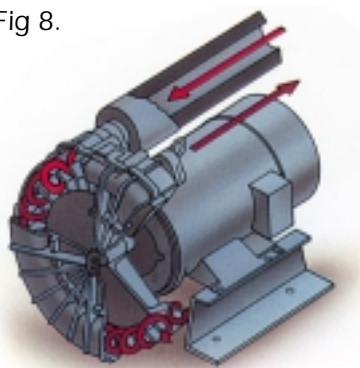

Fox has supplied hundreds of small, quiet, highly reliable Rotron blowers as part of our pneumatic conveying solutions

Hoppers, Inlet Funnels, Transitions

Fox can provide custom-fabricated hoppers and transitions. Design options are virtually unlimited and frequently include features such as multiple inlets, vent and access ports, hinged lids, grates, or screens. Special coatings and food-grade finishes are also available

• For a quotation:

Complete Application Data Sheet on Page 11 and fax to Fox!

• Diverter Valves, Slide Gate

Valves: Fox has supplied hundreds as part of our systems.

• Cyclones, Dust Collectors

It is very important to use a correctly specified air/solids separator for your educator system, which Fox can provide.

• Bulk Bag Unloaders, Volumetric and L-I-W Feeders; Controls

Fox partners with many manufacturers can can easily arrange for a Fox educator conveying systems to be integrated with a bulk bag unloader or feeder, which can then be procured from one supplier with complete system responsibility.

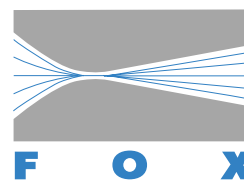
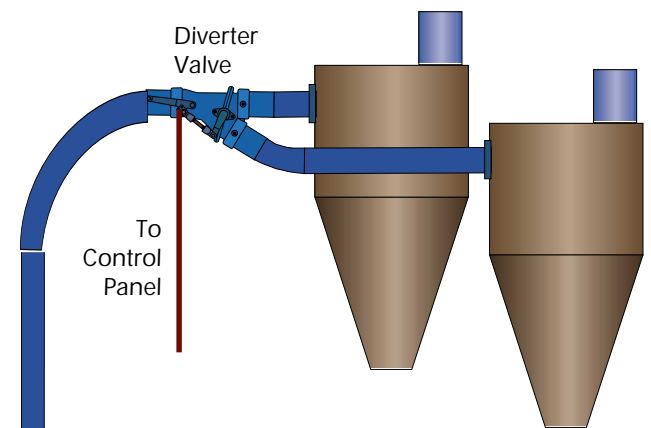

Fox Venturi Eductors
Dover NJ USA
Voice - 973 328 1011
info@foxvalve.com

Wide Radius Bend

Fig 9.

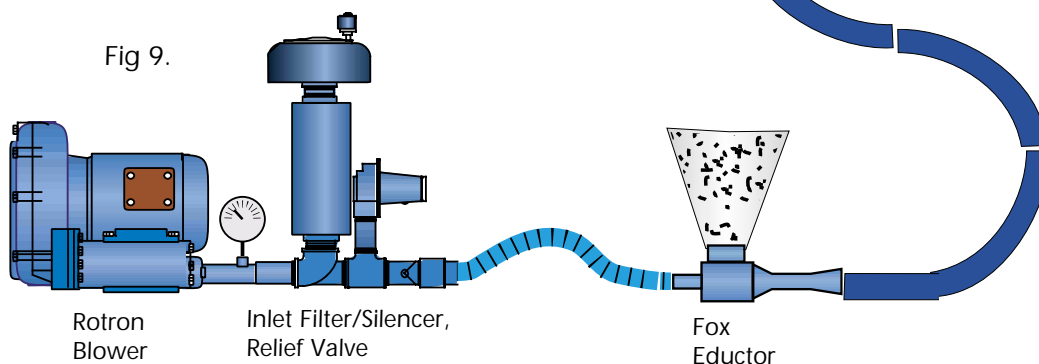

What Type of Eductors are Available?

Having supplied venturi eductors for 40 years, Fox has developed a broad family of eductor designs and styles. Many of these eductor types, which may sound like specials, are in fact maintained in stock and can be shipped in just a few days. In many applications, a blower can also be supplied in a few days

Standard, Off-the Shelf Eductors

Fox maintains exhaustive inventories of stock eductors that can ship in just a few days. A summary:

- **Line Sizes : 1/2" to 6"**
- **Materials: 304 ss, 316 ss, Carbon Steel, Ceramic-Lined**
- **End Connections : NPT, BSP, Flanged, Plain ends**

Of course, eductors can be ordered in any material (Inconel, Hastelloy, ceramic-spray coated, high-release coated).

Fox Ceramic-Lined Venturi Eductors

Highly abrasive products can cause excessive rotary valve wear that can shut down operations. Fox ceramic-lined eductors are to be used with erosive products when long service life and reliability are paramount.

Hardened steel liners are used for high temperatures.

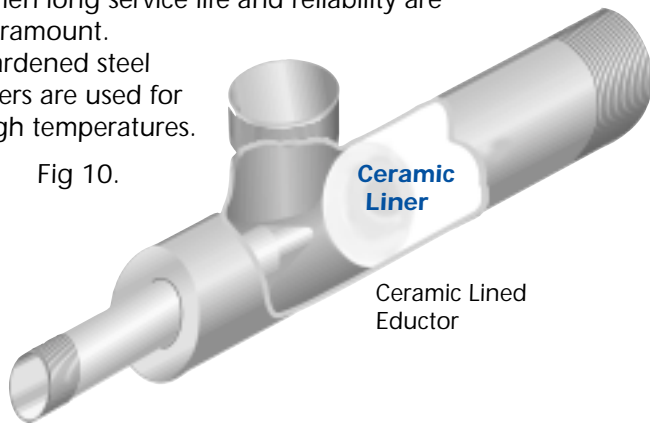
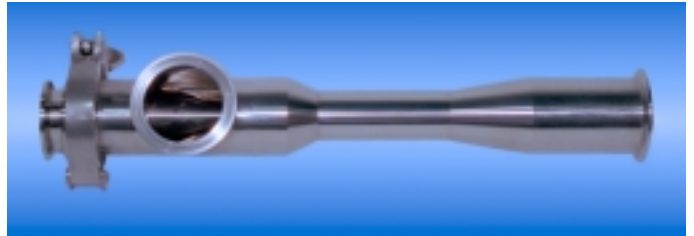

Fig 10.

Ceramic Lined Eductor

Fox Sanitary Venturi Eductors

In applications that demand food grade hardware, Fox offers a complete line of Sanitary Eductors, designed for rapid disassembly in Clean-In-Place (CIP) systems. These eductors are USDA-approved, are built in 304 or 316 ss and have highly polished internals with all welds polished and ground. Fox has extensive experience in conveying fragile food products **without degradation**. Ask for our Bulletin 350.



Enlarged Suction Port Eductors/ Integral Inlet Transitions

All powder inlets do not need to be round, nor small. In order to facilitate installation below dust collectors, or the handling of irregularly shaped materials, Fox eductors can be supplied with a material inlet of any geometry. Enlarged Suction Ports are recommended when handling shredded waste (tires, paper, carpets), chopped cable, fibers, biomass (rice hulls, crushed seeds) or any materials that may bridge above a small opening. Of course, Fox eductors cannot convey material that never leaves the bottom of the hopper, due to bridging.

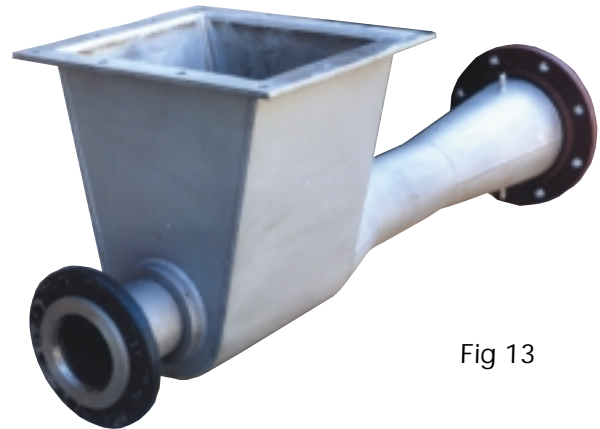

Fig 13

Give Away the Razors... *Sell the Blades ...*

Why There's Always a Bargain-Price Rotary Airlock You Can Buy!

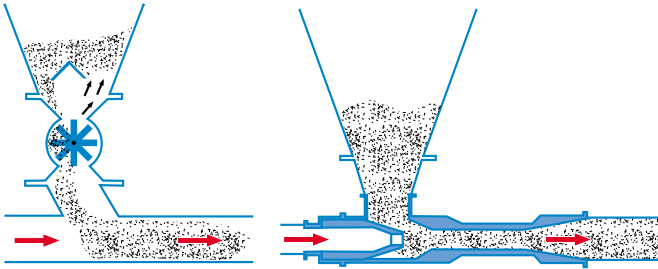

Fig 14.

Suppliers who see excellent profit margins from selling airlock spare parts love to make that first sale of a rotary airlock: that's why you can **always** find a very reasonably priced airlock. Just remember that this first airlock will be just the beginning of your ongoing relationship with this supplier, as you will need to replace bearings, seals, and rotors on an ongoing basis and then, eventually, the airlock itself. The more abrasive your powder (cement, ash, silica, coke, etc.) the more profitable that first airlock sale will be, since it will produce a steady flow of spare parts business later! That's why: There's always a cheaper airlock!

Venting Blowback from Existing Rotary Airlocks...

Fox Rotary Valve Venting Eductors (RVE's) are used to suck blowback air + suspended solids out of the airlock and pneumatically convey them to the destination of choice: bin or silo located above, or the convey line .

What results can we expect from a retrofit with a Fox RVE Venting Eductor?

It depends on how bad your blowback problem was in the first place. But over the last 25 years, we've seen the following widely varied results:

- **Increase in Airlock Feed Rates**
- **Decreased Wear , Increased Service Life**
- **Fugitive Dust - Eliminated**
- **Leakage & Waste - Eliminated**
- **Blowback into Screeners - Eliminated**

Retrofitting/Replacing Existing Rotary Airlocks...

For many reasons, we speak to hundreds of customers anxious to replace their existing rotary airlock with a Fox eductor. The simple answer is that sometimes this is possible, and sometimes this is not.

In this highly competitive sales environment, there is pressure from all parties to reduce costs, particularly if the airlock conveying system was but small component in a larger project. For this reason, the blower and piping are often somewhat undersized, pushing the airlock to the ragged edge of performance and creating the blowback, wear, and failure problems that invite a call to Fox Venturi Eductors.

Replacing an airlock in an existing convey line with a Fox eductor may require changes to the blower or convey line. Fox engineers will provide all necessary sizing information upon receiving a completed Application Data Sheet.

Engineering a venturi eductor into a system at an early design stage is far easier than retrofitting existing equipment.

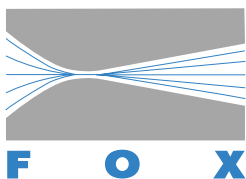

Fox Venturi Eductors
Dover NJ USA
Voice - 973 328 1011, Fax - 3651
info@foxvalve.com

Eductors **DO NOT** Need Compressed Air!!

Less Than 1% of All Fox Eductors Are Driven With Compressed Air (at above 50 psig or 3 barg)

Fox eductors, like all pneumatic conveying systems, very rarely are driven by compressed air at 50 - 100 psig (3+ barg). In 99% of applications, the right solution for the motive air supply is a dedicated blower running at below 14 psig - either a side-channel (Rotron) blower (air at below 3 - 4 psig) or a positive displacement blower supplied as an integral part of the Fox conveying solution.

The idea of "saving money" by not buying a blower and using compressed air is almost always negated by the excessively high cost of air from a compressor. (Note that reducing air pressure from 80 psig

down to 15 psig or 10 psig or 3 psig to drive an eductor has zero effect on the enormous power consumption of a compressor). Moreover, the decision to use compressed air rather than a blower often pushes decisions towards using unusually small convey lines, which may be inappropriate.

The following are some circumstances where using compressed air to drive an eductor may make sense:

- Intermittant operation** - a few minutes per day, or a few times per week;
- Conveying where **cool, dry, or otherwise conditioned air** must be used with low flow rates (1-1/2" lines or below) avoiding the requirement for a cooler to reduce a blower's temperature rise
- Where eductors must discharge into a conveying line or process at 4 psig or higher.

Driving Fox Venturi Eductors with Rotron Blowers... **When 24/7 Reliability is Critical**

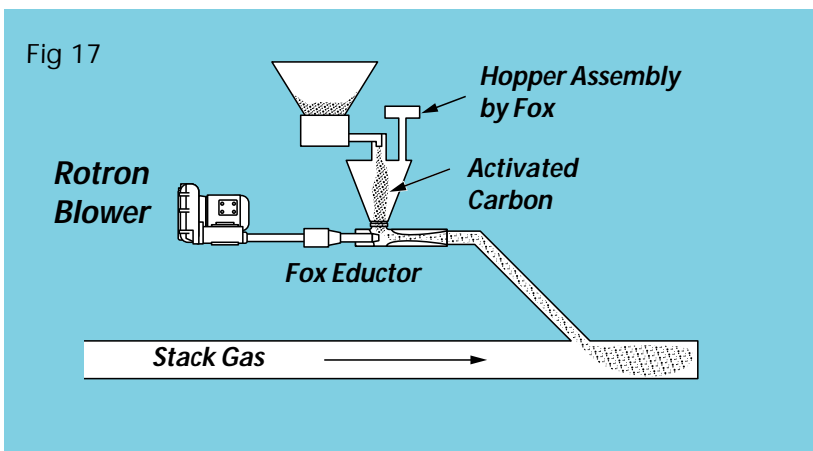

Maintenance-free Fox eductor/blower combinations have proven themselves the right choice in hundreds of plants where 24/7 reliability is critical. This includes activated carbon injection on stack gas emission systems or boiler additive feed for ash or slag conditioning. By contrast, the typical airlock or dense phase system offered by most pneumatic conveying system designers can suffer sudden, catastrophic failure due to their many moving parts: seals, rotating shafts, and bearings.

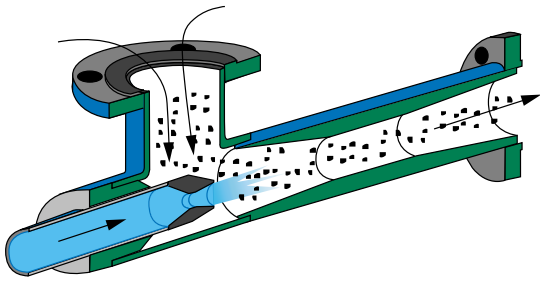

Application Data Sheet Fox Venturi Eductors

Hamilton Business Park • Dover NJ
07801 USA

Ph: 973-328-1011 Fax: 973-328-3651
email: info@foxvalve.com

Fox Venturi Eductors for Conveying Solids

Please provide the requested information so that Fox can prepare a quotation on a performance guaranteed venturi eductor.

Company Name & Address: _____

Email: _____

Contact: _____ Phone no.: _____ Fax: _____

Material To Be Conveyed: _____

Bulk Density _____ Particle Size _____ Max = _____

Temperature: _____ Abrasive Characteristics _____ Free flowing? _____

Moisture or fat content: _____ Max allowable temp (if temp. sensitive) _____

Required Solids Flow Rate: Nominal _____ Max. _____

Distance Mat'l to be Conveyed: Horizontal _____ Vertical _____

Numbers of Elbows: 90° _____ 45° _____ Other _____

Geometry of elbows, i.e. Long, short radius, blind tee, etc (long radius preferred)

Pressure at exit end of Conveying line: _____

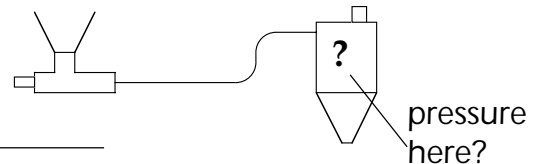

Existing Conveying Line? yes/no If yes, ID = _____

Gravity Feed: Yes No What is eductor fed from? (e.g screener, dust collector)

Should Fox quote hopper or transition? Yes No (If yes, fax sketch)

Preferred End Connections of Eductor: NPT 150# Flgd. Butt Weld

Plain Pipe Tube (inch OD) Tri-Clamp Other _____

Req'd Material of Eductor: Stainless Carbon Steel Wear Treated Sanitary

Motive Air Available: Pressure _____ Motor hp _____

Flow Rate Available, SCFM _____ Blower model, if known _____

Should Fox quote blower? Yes No

Special Requirements:

Please provide a sketch of your pneumatic conveying system.

Website

Dimensional Information — Solids Conveying Eductors

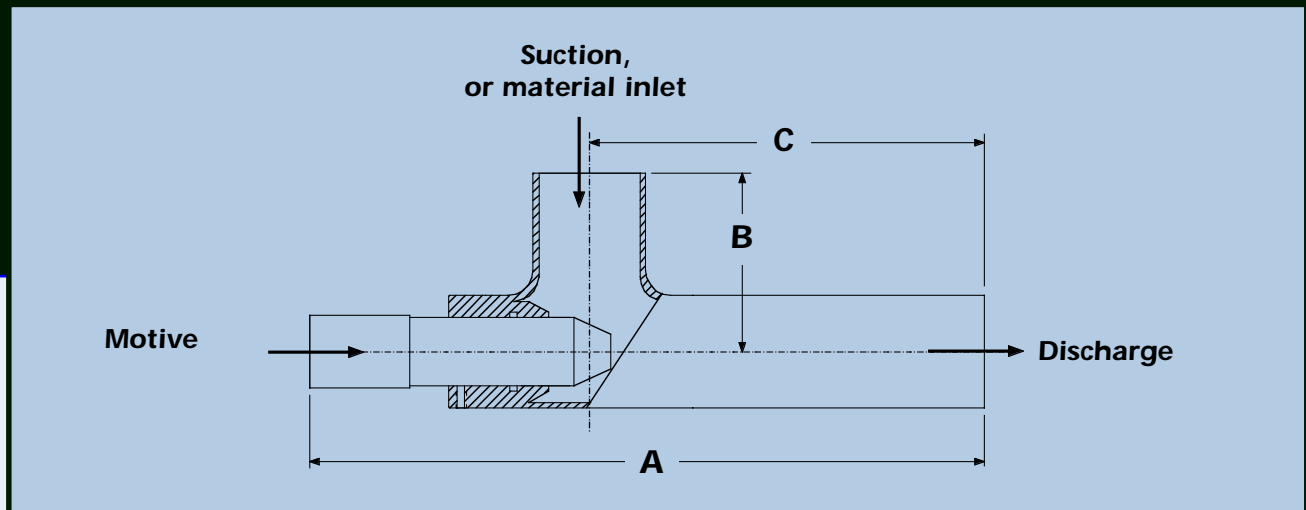

Eductor Discharge/ Line Size	Motive	Suction	A	B	C
1"	1/4"	1"	6.4"	2.5"	5.5"
1-1/2"	1/2"	1-1/2"	7.8"	2.9"	6.0"
2"	1"	2"	12.8"	4.4"	9.6"
2-1/2"	1-1/4"	2-1/2"	15.5"	5.4"	11.9"
3"	1-1/2"	3"	18.8"	5.6"	14.3"
4"	2-1/2"	4"	23.9"	6.8"	18.4"
5"	3"	5"	29.0"	8.6"	22.5"
6"	3"	6"	33.3"	9.8"	26.1"
8"	4"	8"	45.3"	9.5"	42.8"

End Connections

Standard connections are NPT, plain pipe or tube ends, and flanges. Any other connection can be provided, including Victaulic, sanitary, BSP, quick-couplings, DIN flanges or special adaptors.

Material of Construction

Standard materials are :

- Carbon steel
- 304 and 316 stainless
- Ceramic-Lined/ Ceramic Spray Coated
- Tool Steel Lined

Fox can supply eductors in an commercially available material, including Hastelloy, Monel, Alloy 20, Inconel 625, Titanium, etc.

Surface Treatments/Coatings

Dozens of different surface treatments and coatings are available. Fox has applied high release coatings to help inhibit build-up with cohesive materials, as well as various erosion and corrosion resistant surface finishes.

Expedited Delivery

Accelerated delivery is an available option for urgently needed equipment. Contact Fox for a quotation for the applicable Rush Premium to your project schedule.

Quantity Pricing

If you are exploring the integration of a Fox eductor into your OEM equipment, be sure to mention possible quantities in your earliest discussions with Fox. The inclusion of customized features that make the eductor just right for your application may add little or no cost to production quantities.

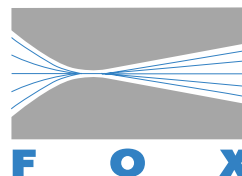

Additional Technical Literature Available Upon Request

To receive any of the following technical information, please just contact us (email, fax, or phone) and request this literature, along with a brief explanation of your possible application:

Brochures

- **Cement Plant Applications** - Bull. 307
- **Food Industry Applications** - Bull. 350
- **Power Industry Applications** - Bull. 308
- **Foundry Applications** - Bull. 317
- **Plastics Industry Applications** - Bull. 336
- **Fox Blower/Eductor Systems** using Rotron or PD Blowers - Bulletin 302
- **Venting Blowback** from Airlocks with Fox RVE Eductors - Bulletin 360
- **Flue Gas Conditioning/Additive Injection** into Ducts with Fox Systems - Bull. 305
- **Slurry Eductors** for Liquid/Powders - Bull. 106
- **Air Ejectors** - Bull. 251
- **Steam Ejectors** - Bull. 201
- **Water Eductors** - Bull. 103

Published Case Histories/Reprints

- Ten Years of Maintenance-Free Conveying with Fox eductors at metal processor
- Cement - Convey Kiln Spill at 700° C with No moving parts
- Cement - Convey waste/alternative fuels into cement kiln with 24/7 reliability
- Power - Spent Bed Recirculation, at high temps, at fluidized bed cogen plant
- Power - Dried sludge injection at cogen power plant
- Pigment powders at dye mfr.
- Foundry: Spent sand Conveying and dust collector retrofit
- Limestone Dust at Mexican mine
- Convey Dense Metal powders at magnet producer

Case Studies

Fox constantly publishes new Case Studies as our venturi eductors are applied by new customers in new applications conveying new products. Here is just a partial list of **Case Studies** that can be emailed or faxed to you upon request, grouped by industry:

Food:

- 63 Corn snacks from extruder
- 59 Frozen cranberries
- 55 Puffed rice from reel
- 50 Oat bran from dust coll.
- 49 Ground coffee; screener
- 42 Cereal; package reclaim
- 39 Sugar; bulk bags
- 34 Whey; spray dryers
- 24 Salt flakes; screw feeder
- 17 Minors; spices - screw fdr.

Plastics

- 45 Cryogenic grinding; mill
- 44 Screener - overs/unders
- 47 Acrawax feed to line
- 4 Reduce streamers and angelhair

Diapers/ Hygenic

- 84 SAP/ Absorbant polymer in diaper production

Building Products

- 79 Pumice/grout from dust collectors
- 83 Ground Cement Boards
- 85 Phenolic Resin at chipboard plants
- 20 Copper pellets, 400 pcf

Minerals/Mines/ Metals

- 20 Copper pellets at 400 pcf
- 70 Copper-based caalciate @ 700* F
- 81 Shredded Aluminum
- 20 Copper pellets, 400 pcf

Cement

- 74 Inject alt fuels/waste (shredded tires, carpets) into cement kiln
- 80 CKD @ 700* F
- 77 Dried sludge into kiln

Power/FGD/Environmental

- 52 Hydrated lime, FGD
- 71 Boiler additive injection
- 72 Activated Carbon inj. into ducts
- 27 Pulverized Limestone, screw feeder
- 78 Dried sludge at cogen plant
- 74 Alt fuels; shredded waste
- 6 Flyash at 700° F

